

User Manual

Hybrid Bidirectional Inverter – PowerStar Rev 1.4

Multi Power Controllers

Multi Power Controller User Manual

Contents

| | | |
|-------|---------------------------------|----|
| 1. | Introduction..... | 7 |
| 1.1 | Warnings and Cautions..... | 7 |
| 1.2 | Contacting MLT Drives..... | 9 |
| 1.2.1 | Product Support..... | 9 |
| 1.2.2 | Contact Details..... | 9 |
| 1.2.3 | Telephone..... | 9 |
| 1.3 | System Configuration..... | 10 |
| 1.4 | System Description..... | 11 |
| 1.5 | Options..... | 12 |
| 1.5.1 | Solar MPPT Regulator..... | 12 |
| 1.5.2 | IO Extender Interface Card..... | 12 |
| 1.5.3 | Computer User Option..... | 13 |
| 2. | Operating..... | 14 |
| 2.1 | Use of the Keypad..... | 14 |
| 2.2 | User Functions..... | 15 |
| 2.2.1 | Power Up/Power Down..... | 15 |
| 2.2.2 | Emergency Stop..... | 16 |
| 2.2.3 | Bypass Switch Operation..... | 16 |
| 2.2.4 | Fault Reset..... | 17 |
| 2.3 | Menu..... | 18 |
| 2.3.1 | Menu Tree..... | 19 |
| 3. | Displaying Information..... | 33 |
| 3.1 | Main Screen..... | 34 |
| 3.1.1 | Operational Modes..... | 34 |
| 3.2 | Overview Screen..... | 35 |
| 3.3 | Load Line Summary..... | 36 |

| | | |
|------|--|----|
| 3.4 | Source Line Summary..... | 36 |
| 3.5 | Source Status Screen | 37 |
| 3.6 | Inverter Line Summary..... | 37 |
| 3.7 | DC Summary Screen | 38 |
| 3.8 | Battery Status Screen | 38 |
| 3.9 | Solar Status Screen..... | 39 |
| | 3.9.1 Current delivered by the Solar (PV) panels | 39 |
| 3.10 | Smart Loads | 39 |
| 3.11 | Summation Logs | 40 |
| 3.12 | Run Hours and Site Logs..... | 40 |
| 3.13 | Miscellaneous Logs..... | 40 |
| 3.14 | Temperatures | 41 |
| 3.15 | System Information | 41 |
| 4. | Connecting External Sources..... | 41 |
| | 4.1 General | 41 |
| | 4.2 Types of Generator | 41 |
| | 4.3 Preparation | 42 |
| | 4.4 Installing a Generator | 42 |
| 5. | About Batteries..... | 46 |
| | 5.1 General | 46 |
| | 5.2 Battery Bank Location | 47 |
| | 5.3 Maintenance | 47 |
| | 5.3.1 Equalisation..... | 47 |
| | 5.3.2 Temperature Compensation | 48 |
| | 5.4 Replacing a Battery | 49 |
| | 5.5 Battery Charging Examples | 51 |
| | 5.5.1 Example 1 | 51 |
| | 5.5.2 Example 2: | 53 |
| | 5.5.3 Example 3 | 55 |

| | | |
|-------|--|----|
| 6. | About Solar Panels | 57 |
| 6.1 | Introduction | 57 |
| 6.2 | Connecting a Solar System to the MPC..... | 57 |
| 6.3 | Configuring the Solar System | 58 |
| 6.4 | Monitoring the Solar System Operation..... | 58 |
| 7. | Smart Load Relay | 59 |
| 7.1 | Introduction | 59 |
| 7.2 | Configuration | 60 |
| 8. | Trouble Shooting..... | 61 |
| 8.1 | Events and Faults..... | 61 |
| 8.2 | Typical Problems | 61 |
| 8.3 | Fault Recovery..... | 63 |
| 8.3.1 | Event Messages | 76 |
| 9. | Glossary | 80 |

List of Tables

| | | |
|----------|---|----|
| Table 1: | MENU → System Config/Setup → System Setup → System Options | 20 |
| Table 2: | MENU → System Config/Setup → System Setup → Source Options | 20 |
| Table 3: | MENU → System Config/Setup → System Setup → Utility Options | 23 |
| Table 4: | MENU → System Config/Setup → System Setup → Battery Options | 23 |
| Table 5: | MENU → System Config/Setup → System Setup → Inverter Options | 27 |
| Table 6: | MENU → System Config/Setup → System Setup → Generator Options | 28 |
| Table 7: | MENU → System Config/Setup → System Setup → Solar Options | 31 |
| Table 7: | MENU → System Config/Setup → System Setup → Relay Options | 32 |
| Table 8: | Fault Messages | 63 |
| Table 9: | Event Messages..... | 76 |

List of Illustrations

| | |
|---|----|
| Figure 1: Typical MPC System | 11 |
| Figure 2: Single Phase 6 kVA MPC System Identifying Connectors, Displays & Controls | 13 |
| Figure 3: Keypad Layout | 14 |
| Figure 4: Bypass Box Circuit | 16 |
| Figure 5: Menu Tree | 19 |
| Figure 6: Screen 1 - Main Screen | 34 |
| Figure 7: Screen 2 - Overview Screen..... | 35 |
| Figure 8: Screen 3 - Load Line Summary..... | 36 |
| Figure 9: Screen 4 – Source Line Summary | 36 |
| Figure 10: Screen 5 – Source Status..... | 37 |
| Figure 11: Screen 6: Inverter Line Summary | 37 |
| Figure 12: Screen 7 – DC Summary | 38 |
| Figure 13: Screen 8 - Battery Status..... | 38 |
| Figure 14: Screen 9 – Solar Status..... | 39 |
| Figure 15: Screen 10 – Smart Loads..... | 39 |
| Figure 16: Screen 11 – Summation Logs..... | 40 |
| Figure 17: Screen 12 – Run Hours and Site Logs | 40 |
| Figure 18: Screen 13 – Miscellaneous Logs | 40 |
| Figure 19: Screen 14 – Temperatures..... | 41 |
| Figure 20: Screen 15 – System Information..... | 41 |
| Figure 21: Single Phase AC Input/Output Connections for One Inverter Module..... | 43 |
| Figure 22: Single Phase AC Input/Output Connections for Multiple Inverter Modules..... | 44 |
| Figure 23: 3-Phase AC Input/Output Connections..... | 45 |
| Figure 24: Danger of Short Circuits when using an Un-insulated Spanner to Connect/Disconnect Batteries..... | 50 |
| Figure 25: Smart Load Relay Outputs on the IO Extender Interface..... | 59 |

1. Introduction

1.1 Warnings and Cautions

A safety instruction (message) includes a hazard alert symbol and a signal word, WARNING or CAUTION. Each signal word has the following meaning:



HIGH VOLTAGE: This symbol indicates high voltage. It calls your attention to items or operations that could be dangerous to you and other persons operation this equipment. Read the message and follow the instructions carefully.



WARNING: Indicates a potentially hazardous situation which, if not avoided, can result in serious injury or death.



CAUTION: Indicates a potentially hazardous situation which, if not avoided, can result in minor to moderate injury, or serious damage to the product. The situation described in the CAUTION may, if not avoided, lead to serious results.

WARNINGS



DANGER OF ELECTRIC SHOCK. There are no user serviceable parts inside either the Control Box or the Inverter Module. **DO NOT** remove covers or open either unit unless on the instruction of MLT Service Engineers.



WARNING: This equipment should be installed, adjusted, and serviced by qualified electrical maintenance personnel familiar with the construction and operation of the equipment and the hazards involved. Failure to observe this precaution could result in bodily injury.



WARNING: The Smart Relay Option and the associated wiring should be installed by a qualified electrician. Failure to observe this precaution could result in bodily injury.

CAUTIONS



CAUTION: The Control Box weighs 11 kgs without inbuilt solar regulator, 16 kgs with built in MPPT regulator and each Inverter Module weighs 61 kgs. When moving the equipment, ensure that there are sufficient people or the correct lifting equipment is available. Always wear personal protective equipment (protective clothing, gloves, and safety boots) to avoid the danger of injuries.



CAUTION: Proper grounds, disconnecting devices, e.g. bypass boxes and other safety devices and their location are the responsibility of the user and are not provided by MLT Drives



CAUTION: Changing any of the settings without consulting MLT or the installation engineer may permanently damage the equipment and override safety features. Overriding safety features may cause possible damage to the inverter, external wiring and electrical equipment which may in turn cause fires damaging property.



CAUTION: Do not cover the device or store it in a small space - always keep it well ventilated well away from flammable gases or powders. Components in the device can cause a small electric spark between contacts that could ignite flammable gas or powders. Flammable gases are created by batteries in poorly ventilated spaces.



CAUTION: For indoor use only and **MUST** be installed in a dry area free from conductive liquids or conductive debris. If part of the inverter becomes submerged in water look for a safe way to isolate it at the distribution board and if possible at the fuses on the front. Water can easily carry deadly electric current so if you are in any doubt call the fire brigade to disconnect the machine.



CAUTION: Configuration and changes to system parameters should only be carried out by trained personnel unless otherwise specifically instructed by MLT support engineers.



CAUTION: **DO NOT** connect solar panels directly to the solar input on a MPC that does not have a built in MPPT regulator.

1.2 Contacting MLT Drives

1.2.1 Product Support

When contacting Product Support via telephone, email or fax please provide the following information for the fastest possible service:

- Type of Inverter
- Serial number
- Software and Firmware version numbers
- Error message shown on display
- Battery type
- Battery bank capacity
- Battery bank voltage
- Options installed

The above details (apart from the “Error Message” should be available from your System Configuration sheet (see page 10). Note that the software and firmware version numbers plus the serial number are available from the System Information screen which is accessed from the SCREENS menu (see System Information on page 41).

1.2.2 Contact Details

Telephone: +27 21 683 3310

Email: info@mltdrives.com

Address: 97 Garfield Road
Kenilworth 7000
Cape Town
South Africa

1.2.3 Telephone

You can reach Technical Support by telephone directly Monday to Friday between 08h00 and 16h30 (GMT +2 hours). Telephone calls outside of these hours will be directed to voice mail and will be answered at the earliest opportunity. When telephoning, please ensure that you have the information listed above available.

1.3 System Configuration

The system configuration table below should be completed by the installer after installing your Multi Power Controller system. We recommend that you check that it is completed as it contains most of the information needed when contacting MLT Drives for assistance.

| Item | Parameter | Description | | | | | | | |
|----------------|------------------------------|-------------|-------------|--------------|----------|-----------|--------|------|----|
| | | 1. | System Type | No of Phases | | kVA | | | |
| 1 | 3 | | | 6 | 12 | 18 | 8 | 16 | 24 |
| 2. | Serial Number | | | | | | | | |
| 3. | Software Versions | | | | | | | | |
| 4. | Bypass Box Fitted | Yes | | | No | | | | |
| 5. | Battery Type | | | | | | | | |
| 6. | Nominal Battery Bank Voltage | 36 Volts | | | 48 Volts | | | | |
| 7. | Battery Bank Capacity | | | | | | | Ah | |
| 8. | Battery Bank Fuse Fitted | Yes | No | Rating = | | | A | | |
| Options | | | | | | | | | |
| | Description | | | | | Installed | | | |
| 9. | Solar Regulator | | | | | MPPT | Linear | None | |
| 10. | IO Extender Interface | | | | | Yes | | No | |
| 11. | Computer User Option | | | | | Yes | | No | |

1.4 System Description

MLT Multi Power Controller (MPC) systems are mechanically and electrically robust and tough with a wide operating temperature range suitable for operation in harsh environments. The MPC has a 150% overload capacity and is the perfect fit for low maintenance, off grid, remote installations and industrial or home power management.

A typical MPC system application is shown below in Figure 1 involving the integration of grid, generator backup power, solar energy and batteries. If required, the system can be managed remotely via a GSM interface, phone line connection or local area network (LAN).

The MPC is available in either single phase or three phase configurations. A single phase system may comprise a Control Box and one, two or three 6 KVA Inverter Modules connected in parallel. The three phase system will always comprise a Control Box and three 6/8 KVA Inverter Modules (one for each phase).

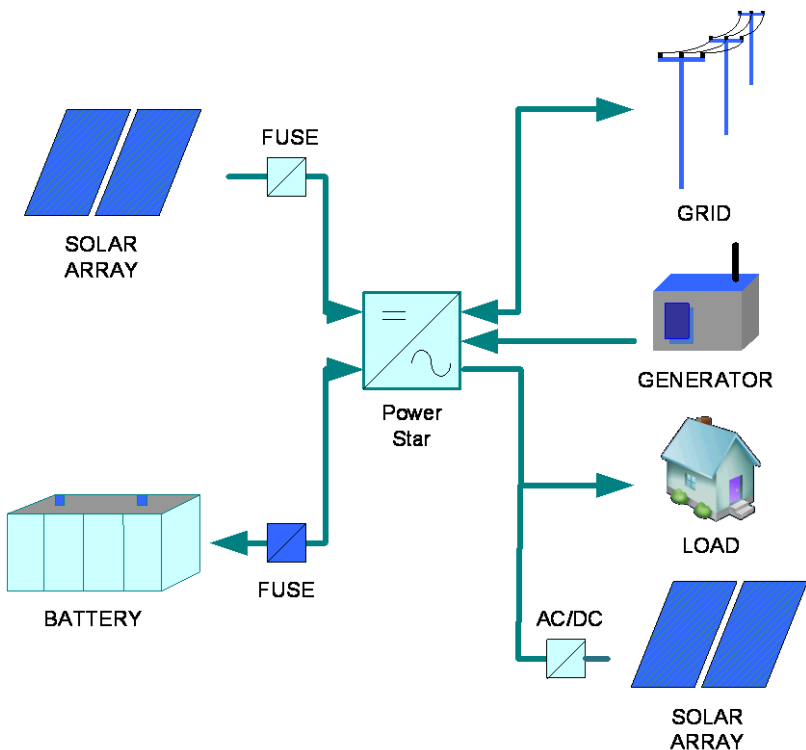

Figure 1: Typical MPC System

The MPC system installed primarily ensures that quality power to the local site load is maintained at all times. The source of power will be the solar energy first and then the AC power source from the grid or generator. Discharging of the battery will only occur if the grid is not present or is out of range.

When no renewable energy is available, the site load will be powered by the grid supply with the Inverter module(s) used to provide reactive energy so as to maintain the load voltage at its nominal value even if the grid voltage varies up to $\pm 15\%$ or as governed by the settings.

If a backup generator is available it can be started automatically and brought on line to supply the load and charge the batteries. The starting can be set to be either a predetermined time or when the battery voltage reaches a predetermined level.

Whilst the AC source is present, the load can be supplied with the combined rating of the AC source as well as that of the inverter rating. In such cases the total power available is the maximum settable load on the AC source and the inverter power rating (which is drawn from the batteries.) The maximum battery charging is governed by the sum of power available from the grid (or generator) and the solar array minus the power consumed by the load at that time.

1.5 Options

1.5.1 Solar MPPT Regulator

The MPPT Regulator allows control of solar panels by finding the point where the most power is obtained from them. Configuration includes selecting the method used to find this point which differs between types and makes of solar panels.

1.5.2 IO Extender Interface Card

The IO Extender Interface Card allows you to enhance the operation of the system by connecting other devices such as Battery Temperature (required for temperature compensation), Solar Radiation, Fuel Level and other Sensors and Emergency Stop, Generator and Load Controls.

Smart Load Relay: If the IO Extender option is installed it allows the configuration for shedding of loads set on a priority of 1 to 3. Here 1 being the most important. The shedding can be dependent on battery status, load level and time-of-day. Note that the IO Extender Interface Card option must be installed to use this option.

1.5.3 Computer User Option

The Computer User Option enables control of the system using a remote PC. Use of this option is covered in a separate publication – contact MLT Drives for further information.

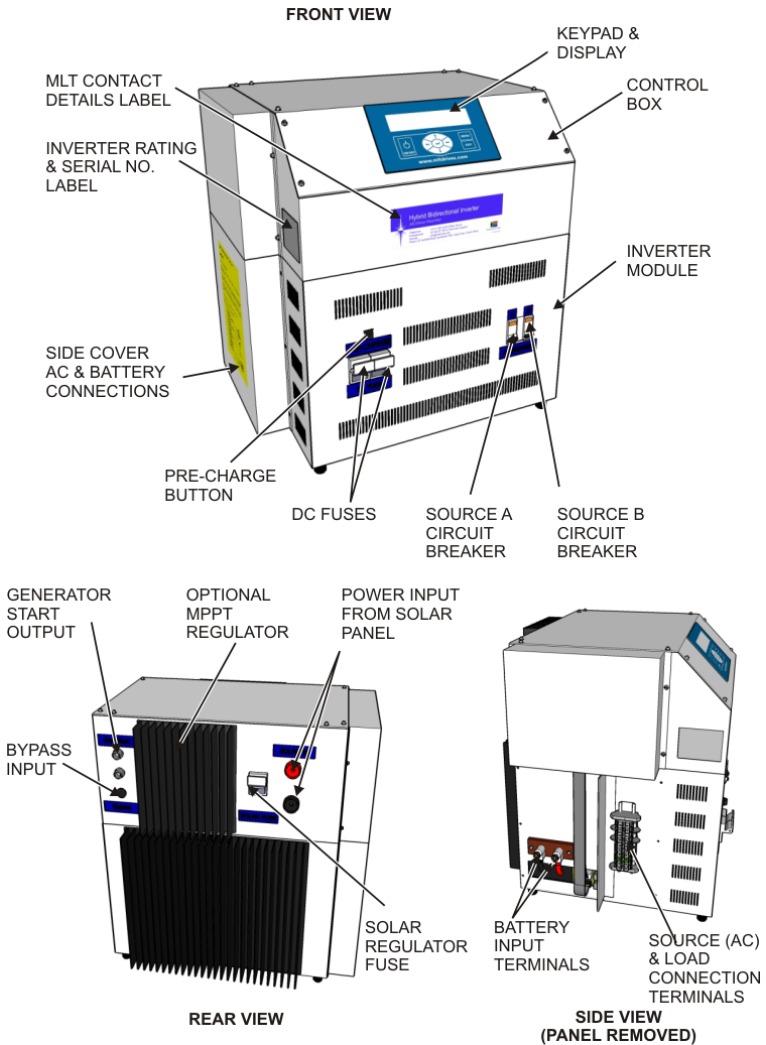

Figure 2: Single Phase 6/8 kVA MPC System Identifying Connectors, Displays & Controls

2. Operating

2.1 Use of the Keypad

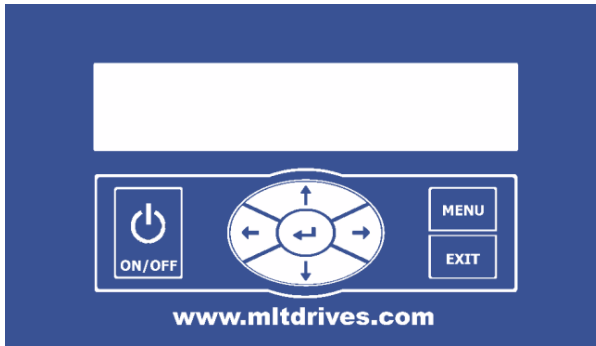

Figure 3: Keypad Layout

ON/OFF Power ON/OFF key:

- Press to start and run MPC in Auto Mode
- Press to stop MPC

Fault Reset:

- Press and hold for 3 seconds to reset MPC when a fault is displayed on line 3 of the display.

MENU

Menu key: Press to access the MPC's menu. Menu options are shown on the display (see Menu on page 18 for further information).

Note that pressing MENU while in the menu exits the current menu and displays the top level menu.

EXIT

Exit key: Press to exit current menu option and go up one level. Any data being entered is cancelled.



Return key:

- When browsing menu, press to select the displayed option
- When entering data or making selections, press to save the current entry



Left/Right Navigation key:



- When in the menu and entering data press to move the cursor one place to the left/right.
- When browsing the menu, press to page UP (←) and DOWN (→) through the current menu options



Up/Down Navigation key:



- Press to browse through available screens.
- When browsing menu, press to scroll through sub-menu options
- When in the menu and changing settings, press to change the current setting, e.g. from YES to NO
- When entering data, press to increase/decrease the selected digit by one

2.2 User Functions

2.2.1 Power Up/Power Down

2.2.1.1 Power down MPC as follows:

- 1) Press **ON/OFF** button on keypad. Display shows "System Off"
- 2) If display shows "Confirmation Required" press  to confirm or **EXIT** to cancel.

NOTE: Confirmation is set to ON or OFF (default OFF) using MENU → System Config/Setup → Keypad Setup → Confirm Power Off.

- 3) If required OPEN AC Breakers and then remove DC Fuses on MPC.

NOTE: Always OPEN AC Circuit Breakers before OPENING DC Fuses.

2.2.1.2 Power Up

Power up MPC as follows:

- 1) Press and hold pressed Pre-Charge button for 3 seconds and then replace DC Fuses.

NOTES: Pressing the Pre-Charge button charges large capacitors inside the MPC thus preventing arcing when the DC fuses are replaced. Use of the Pre-Charge button also prevents wear and tear on the fuses and fuse holders.

Always CLOSE DC Fuses before CLOSING AC Circuit Breakers.

- 2) CLOSE AC Circuit Breakers on MPC.
- 3) If the system was not set up to start automatically (Sys Auto Restart Enabled = NO), press **ON/OFF** button on keypad to switch ON MPC (blank screen).
- 4) Monitor Main Screen display for fault reports

2.2.2 Emergency Stop

In an emergency and if “Power Off Confirmation” is required the MPC can be quickly stopped by OPENING the AC Circuit Breakers and then OPENING the DC Fuses. This method should be avoided unless really necessary. Alternatively an Emergency Stop Pushbutton can be wired into the IO Extender Interface on the Control Box.

2.2.3 Bypass Switch Operation

The Bypass Switch must be fitted when the MPC is connected to the Grid (grid tied). It allows the grid supply to be fed directly through to the load and should be used whenever work has to be carried out on the Control Box, Inverter Module or associated wiring. A typical Bypass Box circuit is shown in Figure 4.

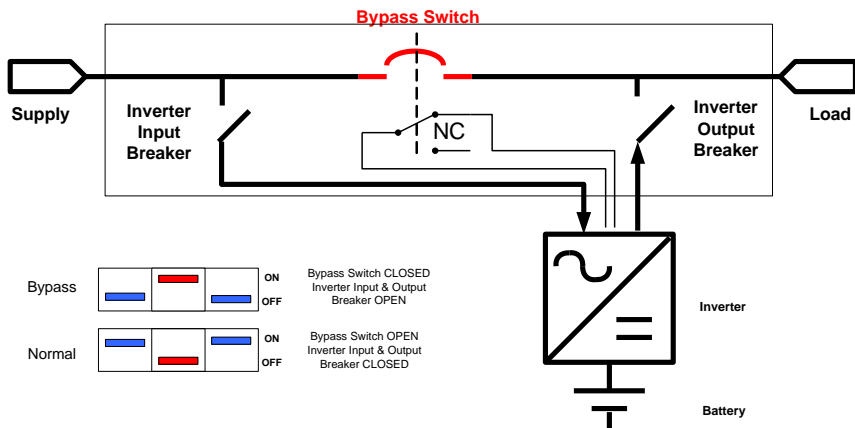

Figure 4: Bypass Box Circuit

2.2.3.1 Bypass Mode



CAUTION: ensure grid and inverter are in sync before closing bypass switch. The inverter is synchronized to the grid if the inverter is in Auto Source Plus Inverter mode. See section 3.1.1 Operational Modes.

To route grid supply directly to load:

- 1) CLOSE (turn ON) **Bypass Switch** on Bypass Box, i.e. route grid supply directly through to load.
- 2) OPEN (turn OFF) **Invert Input** and **Inverter Output** Circuit Breakers on Bypass Box (MPC is now isolated from grid).

NOTE: Wait for at least 30 seconds before recovering from bypass and going to Normal Mode again

2.2.3.2 Normal Mode

To recover from Bypass Mode:

- 1) On completion, CLOSE **Invert Input** and **Inverter Output** Circuit Breakers on Bypass Box.
- 2) Using Keypad select *Functions/Recover from Bypass*.
- 3) Within 30 seconds OPEN **Bypass Switch** on Bypass Box.

2.2.4 Fault Reset

There are two methods of carrying out a Fault Reset as follows:

- 1) Press and hold the Power ON/OFF key for 3 seconds. This will show "Fault Reset" in the Event line on the main screen.
- 2) Using Keypad select *Functions/Fault Reset*. This will show "Fault Reset" in the Event line on the main screen.

2.3 Menu



CAUTION: Configuration and changes to system parameters should only be carried out by trained personnel unless otherwise specifically instructed by MLT support engineers.

The menu structure is divided into user and installer/support engineer levels. The user level menus allow the everyday operation of the system to be monitored and fault conditions reset when required. The menus that allow system parameters to be changed can only be accessed by entering the appropriate password.

2.3.1 Menu Tree

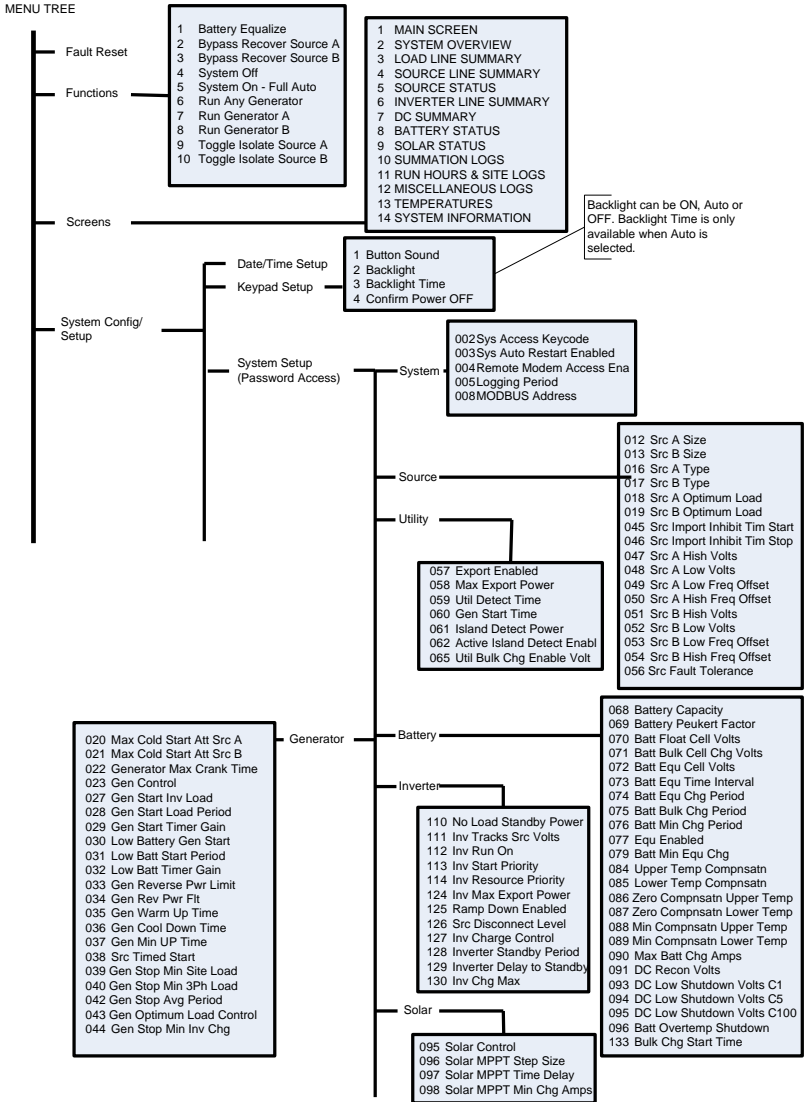

Figure 5: Menu Tree

Table 1: MENU → System Config/Setup → System Setup → System Options

| SP No | Name | Description | Default Values |
|-------|--------------------------|--|----------------|
| 002 | Sys Access Keycode | System Access Keyword: This setting allows the user to specify a four-digit PIN number that needs to be entered to access the System Setup option. For PIN numbers smaller than 1000, please precede the PIN with leading zeros. Be sure that only authorised operators are in possession of the PIN number. | 0001 |
| 003 | Sys Auto Restart Enabled | System Auto Restart Enabled: This option enables the automatic start of the system upon power up or after a power outage. If the start is successful, the system resumes a supply mode. Otherwise, the system enters the 'System OFF' mode and displays the last fault. | NO |
| 004 | Remote Modem Access Ena | Remote Modem Access: Enabled: If set to YES the system expects a locally connected modem and automatically performs the necessary modem management. | Yes |
| 005 | Logging Period | The optional internal data logger. Will take a snapshot log of all data fields such as voltages, currents, temperatures etc periodically in intervals set up by this setting. Data logs are also captured on any event or mode change. | 10 Minutes |
| 008 | MODBUS Address | The Modbus address of the System | 5 |

Table 2: MENU → System Config/Setup → System Setup → Source Options

| SP No | Name | Description | Default Values |
|-------|-----------------------|---|----------------|
| SP12 | Src A Size | Source A/B total kVA capacity. Must not be more than the total kVA of the all the Inverter Modules connected in parallel. | 8 kVA |
| SP13 | Src B Size | | 8 kVA |
| SP16 | Src A Type | Defines Source A/B type, there are three settings: UTIL = Utility Supply (Grid). Also use this setting for a manually started and stopped generator. | UTIL |
| SP17 | Src B Type | GEN = Generator, use this setting if the generator is to be controlled by the MPC. NONE – Use this setting if there is no Source A/B | UTIL |
| SP18 | Source A Optimum Load | Source A Optimum Load indicates the load level that the control system will attempt to maintain on source A while operating in any automatic parallel mode. This setting is expressed as a percentage of the total operating source capacity. | 80% |

| SP No | Name | Description | Default Values |
|-------|----------------------------------|--|----------------|
| SP19 | Source B Optimum Load | Source B Optimum Load indicates the load level that the control system will attempt to maintain on source B while operating in any automatic parallel mode. This setting is expressed as a percentage of the total operating source capacity. | 80% |
| SP45 | Source Import Inhibit Time Start | Form the "Source Import Inhibit Time Start" to "Source Import Inhibit Time Stop" the source will reduce the imported power to zero KW in the event that the source is a UTILITY. If the source was set up to be a GENERATOR and the "Generator Start Time" was disabled then the generator will not be started whilst the time is within the source inhibit time. If a generator however was already running when the source inhibit time starts it will NOT be stopped, but charging continues as normal until it is automatically stopped. When the source is a utility the system will remain connected to the grid while the source is inhibited to allow power export (if enabled) but will not draw any power from the source. When the battery voltage however reaches the low DC threshold the system will start drawing some power to maintain the batteries at this low voltage and to prevent loss of power to the load. To disable this function set both the Start and Stop time to 00:00 | 00h00m |
| SP46 | Source Import Inhibit Time Stop | See "Source Import Inhibit Time Start" | 00h00m |
| SP47 | Src A High Volts | This setting defines the maximum percentage that Source A can go above the System Nominal Voltage (230V) before the control will disconnect Source A and report a "Source A High Voltage" fault. If Source A is a utility (as for a MPC system), it will automatically reconnect when Source A is within normal operating range and the 'Utility Detect Time' has expired. | 111% |
| SP48 | Src A Low Volts | This setting defines the minimum percentage that Source A can go below the System Nominal Voltage (230V) before the control will disconnect Source A and report a "Source A Low Voltage" fault. If Source A is a utility (as for a MPC system), it will reconnect when Source A is within normal operating range and the 'Utility Detect Time' (SP59) has expired. | 89% |
| SP49 | Src A Low Freq Offset | This setting defines the frequency offset from the System Nominal Frequency (50Hz) that Source A can deviate before a 'Low Frequency Fault' is reported. If Source A is a utility, it will reconnect when Source A is within normal operating range and the 'Utility Detect Time' has expired. | 3.0Hz |

| SP No | Name | Description | Default Values |
|-------|------------------------|---|----------------|
| SP50 | Src A High Freq Offset | This setting defines the frequency offset from the System Nominal Frequency (50HZ) that Source A can deviate before a 'High Frequency Fault' is reported. If Source A is a utility, it will reconnect when Source A is within normal operating range and the 'Utility Detect Time' has expired. | 3.0Hz |
| SP51 | Src B High Volts | This setting defines the maximum percentage that Source B can go above the System Nominal Voltage (230V) before the control will disconnect Source B and report a Source B High Voltage" fault. If Source B is a utility, it will reconnect when Source B is within normal operating range and the 'Utility Detect Time' has expired. | 111% |
| SP52 | Src B Low Volts | This setting defines the minimum percentage that Source B can go below the System Nominal Voltage (230V) before the control will disconnect Source B and report a "Source B Low Voltage" fault. If Source B is a utility, it will reconnect when Source B is within normal operating range and the 'Utility Detect Time' has expired. | 89% |
| SP53 | Src B Low Freq Offset | This setting defines the frequency offset from the System Nominal Frequency (50HZ) that Source B can deviate before a 'Low Frequency Fault' is reported. If Source B is a utility, it will reconnect when Source B is within normal operating range and the 'Utility Detect Time' has expired. | 3Hz |
| SP54 | Src B High Freq Offset | This setting defines the frequency offset from the System Nominal Frequency (50HZ) that Source B can deviate before a 'High Frequency Fault' is reported. If Source B is a utility, it will reconnect when Source B is within normal operating range and the 'Utility Detect Time' has expired. | 3Hz |
| SP56 | Src Fault Tolerance | Depicts the source voltage tolerance percentage from the nominal system voltage that can be tolerated for 3ms before the source is taken off line with a Src Fault Tolerance fault shown | 30% |

Table 3: MENU → System Config/Setup → System Setup → Utility Options

| SP No | Name | Description | Default Values |
|-------|---------------------------|--|----------------|
| 057 | Export Enabled | Option to export power to the utility if excess renewable energy is available. | No |
| 058 | Max Export Power | The 'Maximum Export Power (%)' that can be delivered (exported) to a source. For a Grid connected system, this setting should be set to 100% to export as much renewable energy as possible to the utility. For a "Generator Sourced" system, this set point should be set to 0% to prevent reverse powering the generator. Generally, 100% is equivalent to the rated power capacity per phase of the source. If set point 057 is set to 'NO' then it sets the export power to 0% regardless of the 'Maximum Export Power' setting. | 100% |
| 059 | Util Detect Time | Utility Detect Time: Minimum time that the utility parameters must be within range before the utility is considered to be 'Good' and can be connected to the load. | 10 sec |
| 060 | Gen Start Time | Generator Start Time: This is the time after the utility has failed and the respective source is 'BAD' after which the backup generator is started. When this setting is enabled the generator will not automatically stop. To disable this setting set the time to 00:00. | 0 |
| 061 | Island Detect Pwr | Island Detect Power: Shift in power for detecting grid islanding conditions on MPC systems. This set point is expressed as a percentage of the nominal per phase rating of the inverter | 2% |
| 062 | Activ Island Detect Enabl | Active Island Detect Enable: Enable island detection. Islanding may occur if the inverter is set up not to track the source voltage (Inv Tracks Source Voltage = NO) and should always be enabled in this instance. | Yes |
| 065 | Util Bulk Chg Enable Volt | Utility Bulk Charge Enable Volts: If the battery voltage drops below this setting a 'bulk' charge will be initiated at the time set by the Bulk Chrg Start Time SP133. This setting has no effect if the Bulk Chrg Start Time is set to zero. | 1.95 |

Table 4: MENU → System Config/Setup → System Setup → Battery Options

| SP No | Name | Description | Default Values |
|-------|------------------|--|----------------|
| 068 | Battery Capacity | Rated Ampere Hour Capacity of the batteries at 5 hour discharge (C5) time. | 0600Ah |

| SP No | Name | Description | Default Values |
|-------|--------------------------|--|----------------|
| 069 | Battery Peukert Value | Rated Battery Peukert Value. See battery manufacturer's specification. This setting is used to calculate the battery state of charge (SOC). | 1.21 |
| 070 | Batt Float Cell Volts | Battery Float Cell Volts: The float charge voltage level per cell for the system battery bank. Since the float cell voltage is a temperature compensated value, this set point should be set to the value where there is no compensation, which is typically at about 25°C. | 2.14 VPC |
| 071 | Batt Bulk Cell Chg Volts | Battery Bulk Cell Charging Voltage Per Cell: The voltage level that the batteries must achieve during the constant current charge phase. After the bulk voltage is reached, the battery current is tapered down for the Battery Bulk Charge Period (SP75). After this time, the control then maintains the float voltage (SP70). Consult battery manufacturer for the bulk charge voltage. Since the bulk cell voltage is a temperature compensated value, this set point should be set to the value where there is no compensation, which is typically at about 25°C. | 2.32VPC |
| 072 | Batt Equ Cell Volts | Battery Equalisation Charge Voltage Per Cell: This setting defines the equalisation voltage level of the battery bank. Consult battery manufacturer for equalisation voltage and equalisation frequency. This setting is not used when sealed batteries are used. Since the battery equalisation cell voltage is a temperature compensated value, this set point should be set to the value where there is no compensation, which is typically at about 25°C. | 2.40VPC |
| 073 | Batt Equ Time Interval | Battery Equalisation Time Interval: This set point determines the time between equalisation charge cycles in hours. | 0744Hrs |
| 074 | Batt Equ Chg Period | Battery Equalisation Charge Period: This sets the maximum time the system will remain in the battery equalisation-charge region. This set point prevents prolonged charging of the batteries, which may not reach Battery Minimum Equalisation Charge (SP79) due to a high internal resistance of the battery (which can be due to progressive ageing of the batteries). The equalisation - charge cycle will end if this set point is reached or the Battery Minimum Equalisation Charge (SP79) limit has been reached. | 02h00m |

| SP No | Name | Description | Default Values |
|-------|---------------------------|---|----------------|
| 075 | Batt Bulk Chg Period | Battery Bulk Charge Period: This set point sets the maximum time the system will remain in the battery bulk-charge cycle. This set point prevents prolonged charging of the batteries, which may not reach Battery Minimum Bulk Charge (SP76) due to a high leakage on the batteries (which can be due to progressive ageing of the batteries). The bulk-charge cycle will end if this set point is reached or the Battery Minimum Bulk Charge (SP76) limit has been reached. | 02h00m |
| 076 | Batt Min Bulk Chg | Battery Minimum Bulk Charge: The bulk-charge will terminate if this set point is reached or the Battery Bulk Charge Period (SP75) has expired. This set point is expressed as a percentage of the battery shunt size (SP67). | 10% |
| 077 | Equ Enabled | Equalisation Enabled: If this set point is enabled, the control system will periodically attempt to equalise the batteries to the equalisation cell voltage. Set to NO for sealed batteries and YES for flooded lead acid batteries. | NO |
| 079 | Batt Min Equ Chg | Battery Minimum Equalisation Charge: The equalisation-charge cycle will end if this set point is reached or the Battery Equalisation Charge Period (SP74) has expired. This set point is expressed as a percentage of the battery shunt size (SP66). | 5% |
| 82 | Batt Taper To Float Rate | This setting governs the time taken for the battery voltage to drop from the pre-defined Bulk or Equalise battery voltage to the Battery Float Cell Voltage (SP70). This setting only applies during the final stage of the Bulk and Equalisation charge cycles | 05m00s |
| 084 | Upper Temp Compnsatn | Upper Temperature Compensation: This set point specifies the temperature compensation applied to the batteries between Zero Compensation Upper Temperature (SP86) and Minimum Compensation Upper Temperature (SP88). | 5.5 mV/°C |
| 085 | Lower Temp Compnsatn | Lower Temperature Compensation: This set point specifies the temperature compensation applied to the batteries between Maximum Compensation Lower Temperature (SP89) and Zero Compensation Lower Temperature (SP87). | 5.5 mV/°C |
| 086 | Zero Compnsatn Upper temp | Zero Compensation Upper Temperature: For some batteries, there is no temperature compensation of the battery voltage over a defined temperature range. This set point defines the temperature limit at which temperature compensation will start for temperatures higher than this set point. Upper Temperature Compensation (SP84) defines the compensation applied for temperatures above this set point | 30°C |

| SP No | Name | Description | Default Values |
|-------|----------------------------|---|----------------|
| 087 | Zero Compnsatn Lower temp | Zero Compensation Lower Temperature: For some batteries, there is no temperature compensation of the battery voltage over a defined temperature range. This set point defines the temperature limit at which temperature compensation will start for temperatures lower than this set point. Lower Temperature Compensation (SP85) defines the compensation applied for temperatures below this set point | 2°C |
| 088 | Min Compnsatn Upper Temp | Minimum Compensation Upper Temperature: This set point defines the maximum temperature at which temperature compensation of the battery voltages does not change with temperature. The compensation at this set point will be used for temperatures above this set point | 50°C |
| 089 | Min Compnsatn Lower Temp | Minimum Compensation Lower Temperature: This set point defines the minimum temperature at which temperature compensation of the battery voltages does not change with temperature. The compensation at this set point will be used for temperatures below this set point | 1°C |
| 090 | Max Batt Chg Amps | Maximum Battery Charge Amperes: This set point controls the maximum amount of the combined renewable and inverter charging current into the batteries and is expressed as a percentage of the battery shunt size. This set point is used if large renewable sources are available and they can generate currents that exceed the safe maximum charge current limits of the battery bank. | 50% |
| 091 | DC Recon Volts | DC Reconnect Voltage: This set point identifies at what terminal voltage the inverter can automatically re-connect after it has shutdown with a 'Low DC Volts'. It assumes that the renewable input has recharged the battery. | 2.25 VPC |
| 093 | DC Low Shutdown Volts C1 | DC Low Shutdown Voltage C1: If the DC voltage drops below discharge rate C1 for 10 seconds, the system will shutdown due to a 'Low Battery Volts' fault. | 1.7VPC |
| 094 | DC Low Shutdown Volts C5 | DC Low Shutdown Voltage C5: As for 093 but measured at discharge rate C5. | 1.8VPC |
| 095 | DC Low Shutdown Volts C100 | DC Low Shutdown Voltage C100: As for 093 but measured at discharge rate C100. | 1.85VPC |
| 096 | Batt Overtemp Shutdown | Battery Over Temperature Shutdown: The temperature of the battery bank where the Inverter will be shutdown with a "Battery Over Temp" fault indicated | 48°C |

| SP No | Name | Description | Default Values |
|-------|---------------------|---|----------------|
| 133 | Bulk Chg Start Time | Bulk Charge Start Time: Defined as the time an automatic bulk or equalize charge of the batteries could occur provided the bulk charge flag was set as per SP65. If this time is set to 00:00 systems will do a bulk charge whenever a source connects. On systems with very erratic grid supply use this setting to prevent multiple bulk charge cycles per day. | 00h00m |

Table 5: MENU → System Config/Setup → System Setup → Inverter Options

| SP No | Name | Description | Default Values |
|-------|-----------------------|--|----------------|
| 110 | No Load Standby Power | No Load Standby Power represents the % of the total inverter power that must be detected as load in order to recover from Standby mode. To disable load sensing on any systems set this setting to zero. | 00.0% |
| 111 | Inv Tracks Src Volts | Inverter Tracks Source Volts: If set to YES, the inverter will track to the external source voltage when in parallel mode, otherwise it will track to the internal reference voltage, System Nominal Voltage (230V). | NO |
| 112 | Inv Run On | Inverter Run ON: If this set point is set to YES and Source A and Source B cannot successfully be brought on line whilst running in Full Auto, the system will continue to supply power to the site from the inverter until a 'Low DC Link Voltage' shutdown occurs. If it is set to NO, the system will move to a Standby mode. | YES |
| 113 | Inv Start Priority | Inverter Start Priority: This set point defines if the inverter has start priority. If this set point is set to YES then during the FULL AUTO mode, the inverter will be the first resource to come online before any other source. If it is set to NO, either Source A or Source B will be the first resource to come online before the inverter. | YES |
| 114 | Inv Resource Priority | Inverter Resource Priority: If this set point is set to YES, the inverter will remain online if there is a synchronisation fault while the paralleling source will be taken temporarily offline. If it is set to NO, the paralleling source will remain online and the inverter will be temporarily taken offline when a synchronisation fault occurs. | YES |
| 124 | Inv Max Export Power | Inverter Maximum Export Power: This is the maximum exported power or current per phase (as a % of the inverter per phase size) before the solar import will start backing off. | 100 |

| SP No | Name | Description | Default Values |
|-------|-------------------------|---|----------------|
| 125 | Ramp Down Enabled | Ramp Down Enabled: When enabled, it initiates a gradual shift of load from the source that is coming off line to the one that will be remaining on line. This will be applicable when bringing off line Source A or B or bringing the inverter module off line. | YES |
| 126 | Src Disconnect Level | Source Disconnect Level: The level at which the source being disconnected will actually disconnect from the AC bus. Represented as a % of the individual source capacity | 10 |
| 127 | Inverter Charge Control | Inverter Charge Control is used when the inverter is running in stand alone mode. The output frequency of the inverter is increased by this setting when the battery voltage rises above target voltage. | 0%/mV |
| 128 | Inverter Standby Period | Inverter Standby Period | 00m10s |
| 130 | Inv Chg Max | Inverter Charge Maximum: This set point represents a percentage of the rated per phase kW capacity of the inverter that the control will commit for battery charging. This should be set in accordance with the C - rating of the battery bank. It should be noted that this set point is different to SP90 (Maximum Battery Charge Current), which controls the amount of current into the batteries from the renewable source and the inverter. | 20%/Phase |

Table 6: MENU → System Config/Setup → System Setup → Generator Options

| SP No | Name | Description | Default Values |
|-------|--------------------------|--|----------------|
| SP20 | Max Cold Start At Src A | Maximum Cold Start Attempts Source A/B which is the number of attempts that will be made to bring Source A online before the control reports a fault. Set to 0 (zero) if the Source is a grid, i.e. the control will continuously try to bring this source online. | 0 |
| SP21 | Max Cold Start At Src B | | 3 |
| SP22 | Generator Max Crank Time | Generator Maximum Crank Time: This is the maximum time that a generator starter will be cranked. Cranking will terminate 1 second after the generator voltage is within specification. | 00m04s |

| SP No | Name | Description | Default Values |
|-------|-----------------------|--|----------------|
| SP23 | Gen Control | For a MPC system where both Source A and Source B are generators, this setting defines the Generator control configuration of the Generators. In the EQU L configuration, the system will select which Generator to start based on the current Generators' run-hours in an attempt to equalize the run-hours. In the BACK A (Backup A) or BACK B (Backup B) configuration, the system will primarily use one source, however in the event of a failure; the system will resort to the back-up Generator. If BACK A is selected, Generator A will be the back-up Generator and Generator B will be the primary Generator. If BACK B is selected, Generator B will be the back-up Generator and Generator A will be the primary Generator. If the system is running on the back-up Generator and the primary Generator becomes operational, the system will revert to the primary Generator at the next appropriate time to swap Generators. NOTE: For a grid connected system, this setting is of no relevance. | EQU L |
| 027 | Gen Start Inv Load | Generator Start Inverter Load: This setting determines the stand-alone inverter per phase load level, which a generator will automatically start and then connect. This set point is measured as a percentage with respect to the rated per phase capacity | 80%/Phs |
| 028 | Gen Start Load Period | Generator Start Load Period: The integration delay before a generator is started and brought on line due to a high load level on the inverter. This timer is modified by the over load error and SP29. | 120 sec |
| 029 | Gen Start Timer Gain | Generator Start Timer Gain: The 'Generator Start Load Period' (SP28) is modified by this value. The delay before a generator connects automatically shortens by how far the load set point (SP27) is exceeded. | 1.5 sec/% |
| 030 | Low Batt Gen Start | Low Battery Generator Start Volts: This set point determines the stand-alone low battery voltage level per cell at which a generator will automatically start and connect. NB: This set point is not temperature compensated. | 1.95V |
| 031 | Low Batt Start Period | Low Battery Start Period: If the 'Low Battery Generator Start Volts' (SP030) is reached, this set point determines the integration time for which the low battery condition must exist before a generator is automatically connected. | 120 sec |
| 032 | Low Batt Timer Gain | Low Battery Timer Gain: This is the timer modifier associated with 'Low Battery Start Period' (SP31). A generator will start and connect earlier than the preset time when batteries are severely low. | 5 sec/mV |

| SP No | Name | Description | Default Values |
|-------|--------------------------|---|----------------|
| 033 | Gen Reverse Pwr Limit | Generator Reverse Power Limit: When a generator is online, this set point governs the maximum amount of reverse power that the generator will tolerate before shutting down with a Reverse Power Fault. This set point is expressed as a percentage of the nominal rating per phase of Generator A or Generator B. This set point does not apply to the grid supply inputs on grid connected systems. | 10% |
| 034 | Gen Reverse Pwr Flt Time | Generator Reverse Power Fault Time: This set point is the integration time before a generator will fault with the detection of reverse power. If a separate generator control unit is installed, this set point is not used. This set point is used when the power into the generator exceeds the Generator Reverse Power Limit set point (SP33). | 10 sec |
| 035 | Gen Warm Up Time | Generator Warm Up Time: When the generator starts, a warm up time is required before a load maybe applied. This set point determines the minimum start idle delay time before the generator is connected on line. This set point does not apply to the grid supply inputs on MPC systems. | 10 sec |
| 036 | Gen Cool Down Time | Generator Cool Down Time: Once a generator is disconnected from a load, it typically requires a cool down period. This is especially important with turbo charged diesel generators. View generator documentation for the recommended period. | 10 sec |
| 037 | Gen Min UP Time | Generator Minimum Up Time: Once a generator is started, it should typically run for a minimum period on load before being stopped. This ensures even mechanical wear and stress on parts. This can also be used to avoid short start-stop cycles. This setting indicates the minimum generator run period before it may be turned off by the control system. | 15 minutes |
| 038 | Src Timed Start | Source Timed Start: This setting is the time after which the generator is automatically started and brought on line to run for the minimum run time (SP37). Setting to 00:00 will negate the auto start | 168 Hours |
| 039 | Gen Stop Min Site Load | Generator Stop Minimum Site Load: The generator loading per phase must be below this set point before the generator is stopped. This set point is measured as a per phase percentage with respect to the inverter capacity (SP104) | 70% |
| 040 | Gen Stop Min 3Ph Load | Generator Stop Minimum 3-Phase Site Load: The generator total loading must be below this set point before the generator is stopped. This set point is measured as a percentage with respect to the total inverter capacity (SP104). | 50% |

| SP No | Name | Description | Default Values |
|-------|----------------------|--|----------------|
| 042 | Gen Stop Avg Period | Generator Stop Average Period: This set point is the integration time for all the generator stopping decisions. All conditions must be maintained for this time before the generator is stopped. | 120 sec |
| 044 | Gen Stop Min Inv Chg | Generator Stop Minimum Inverter Charge: This is the minimum percentage of the rated per phase capacity of the inverter that the control will commit to battery charging before a generator can be stopped. This set point must be smaller than the Inverter Charge Maximum set point (SP125) | 30% per Phase |

Table 7: MENU → System Config/Setup → System Setup → Solar Options

| SP No | Name | Description | Default Values |
|-------|-------------------------|---|----------------|
| 97 | Solar Control | <p>Solar Control sets the type of solar control that is done on the system</p> <p>0 - Solar Control Disabled 1 - Solar Charge Regulator Only 2 - Solar MPPT Hill-climbing 3 - Solar MPPT Sweeping 4 - Solar MPPT Hill-climbing & Sweeping 5 - Solar Preset Power Point.</p> <p>When the solar regulator is set up for any automatic PPT function and the current offset calibration is set to zero, the system will perform auto-calibration of the shunt offset at every power up instance.</p> | 0 |
| 99 | Solar MPPT Time Delay | Solar MPPT Time Delay is the step delay time in seconds. This is the amount of time the system will delay before taking any increase or decrease in solar voltage during sweeping or hill-climbing. | 100 |
| 103 | Solar MPPT Min Chg Amps | Solar MPPT Minimum Charging Amps: When the current from the solar panel input was detected to be too low the MPPT will be suspended until the current from the solar panels rises above this threshold. This setting is calculated as a % of the Solar Shunt Size. | 2 |

Table 8: MENU → System Config/Setup → System Setup → Relay Options

| SP No | Name | Description | Default Values |
|--------------|-------------------------|--|--------------------------------|
| 138 | Aux Relay 1 Func | This auxiliary relay can be set up for 1 out of 11 functions: 0 = Smart Load A 1 = Smart Load B 2 = Smart Load C 3 = RF Controlled Smart Loads 4 = Fault Alarm Output 5 = Start A (Coil) 6 = Start B (Coil) 7 = External Inverter Fan Control 8 = External Solar Relay 9 = Generator A Starter (Crank) 10 = Generator B Starter (Crank) | Start A (Run Signal for Gen A) |
| 139 | Aux Relay 2 Func | This auxiliary relay can be set up for 1 out of 11 functions (See function options from Aux Relay 1 above) | Start B (Run Signal for Gen B) |
| 140 | Aux Relay 3 Func | This auxiliary relay can be set up for 1 out of 11 functions (See function options from Aux Relay 1 above) | Smart Load A |
| 141 | No. of Smart Loads | This is the total number of connected smart loads. There may only be 3 locally connected smart loads OR up to 5 RF (Radio Controlled) Smart Loads. Smart load A has the highest priority while smart load E will be the lowest and will be disconnected first when load shedding needs to occur. To disable the smart load operation set this setting to zero ('0'). | 0 |
| 142 | Smart Load Relay Wait | Before any new smart-load will be connected or disconnected all conditions granting the change in load must be valid for this period. | 30 |
| 143 | Smart Load Inv Load ON | This is a percentage of the inverter per phase export capacity below which all phases must operate before a smart load level will be incremented. | 50% |
| 144 | Smart Load Inv Load OFF | This is the percentage of the total inverter per phase size that any phase export power must exceed before the smart load level will be decremented | 70% |
| 145 | Smart Load Bat VPC ON | Battery per cell voltage that the battery must be above before the smart load level will be incremented. To disable this setting set the Smart Load Bat VPC OFF the same as Smart Load Bat VPC ON. | 2.1 |

| | | | |
|-----|---------------------------|---|-------|
| 146 | Smart Load Bat VPC OFF | Battery per cell voltage that the battery must be below before the smart load level will be decremented. To disable this setting set the Smart Load Bat VPC OFF the same as Smart Load Bat VPC ON. | 1.97 |
| 147 | Smart Load Disch Amps ON | Battery discharge current % that the battery must be below before the smart load level will be incremented. This is a percentage of the battery shunt size setting. To disable this setting set it to zero. | 50% |
| 148 | Smart Load Disch Amps OFF | Battery discharge current % that the battery must exceed before the smart load level will be decremented. This is a percentage of the battery shunt size setting. To disable this setting set it to zero. | 70% |
| 149 | Smart Load Solar Amps ON | Solar charge current that must be exceeded before the smart load level will be increased. To disable this setting set it to zero. This is a percentage of the solar shunt size. | 0% |
| 150 | Smart Load Solar Amps OFF | If the solar charge current drops below this setting the smart load level will be decremented. To disable this setting set it to zero. This is a percentage of the solar shunt size. | 0% |
| 151 | Smart Load Time ON | Smart loads can be set up to only operate during certain times of the day. Set this setting up for the start time that smart loads will be incremented. To disable this setting set this and Smart Load Time OFF to zero. | 00h00 |
| 152 | Smart Load Time OFF | Smart loads can be set up to only operate during certain times of the day. Set this setting up for the stop time that smart loads will be decremented. To disable this setting set this and Smart Load Time ON to zero. | 00h00 |

3. Displaying Information

Normally, when the MPC is switched on the Main Screen is displayed (see Figure 6) which displays system status information. There are a number of other screens available which are accessed via the FUNCTIONS menu.

Each screen is described below.

NOTE: In the screen displays + = FROM and - = TO.

3.1 Main Screen

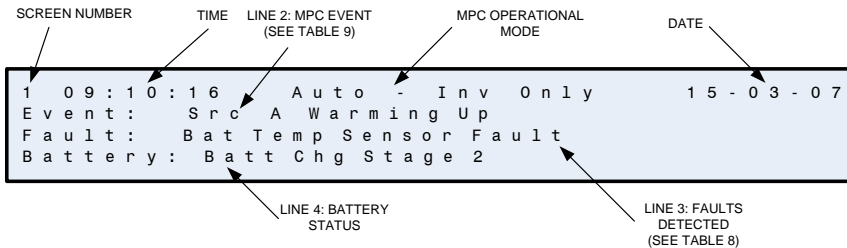

Figure 6: Screen 1 - Main Screen

3.1.1 Operational Modes

Auto – Inv Only: Automatic Inverter Only Mode - The load is supplied directly from the batteries and available renewable DC sources only. ‘Auto’ mode is the mode that the MPC should be run in unless another specific mode is required. Auto mode manages operations automatically, starting and stopping generators, charging batteries, etc. This mode is selected from the FUNCTIONS menu using the SYSTEM ON – FULL AUTO option.

Auto Inv + Src A or B: In this mode the source such as grid or generator would be on-line and used. The load is supplied from the Source and from the DC sources such as batteries and photovoltaic.

Auto Src A or B: In this mode the inverter is turned off and only energy from the source such as the grid or generator is used. Batteries will not be charged from the AC source or used to supply the load. This mode will be used when the inverter is temporarily disabled because it has been previously bypassed or has encountered a problem.

3.2 Overview Screen

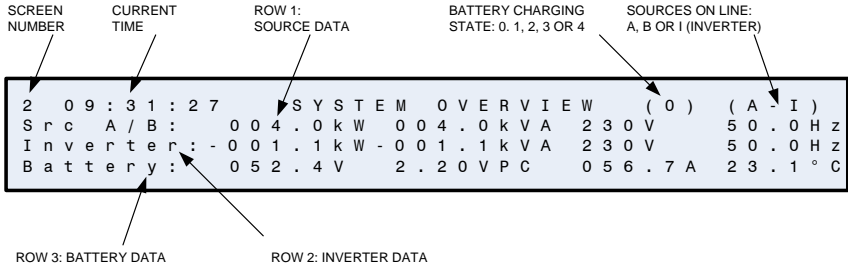

Figure 7: Screen 2 - Overview Screen

Row 2: Source A or B characteristics (Source A is indicated in Figure 7):

004.0 kW – Real Power from the grid

004.0 kVA - Apparent Power from the grid (includes Reactive Power)

230 V - Source Voltage

50.0 Hz - Frequency of the Source

Row 3: Inverter characteristics:

-001.1 kW – Real Power into the inverter

001.1 kVA - Apparent Power from the grid (includes Reactive Power)

230 V - Inverter and Load Voltage

50.0 Hz – Inverter and Load Frequency

Row 4: Battery Status:

52.4V - Instantaneous Battery Voltage

2.2 VPC - Voltage Per Cell (Nominal Battery Cell Voltage is 2.00 VPC)

56.7 A - Total current from or into the batteries (Positive value indicates batteries charging)

23.1°C - Temperature of the batteries (only displayed if optional extra battery temp monitor is fitted).

3.3 Load Line Summary

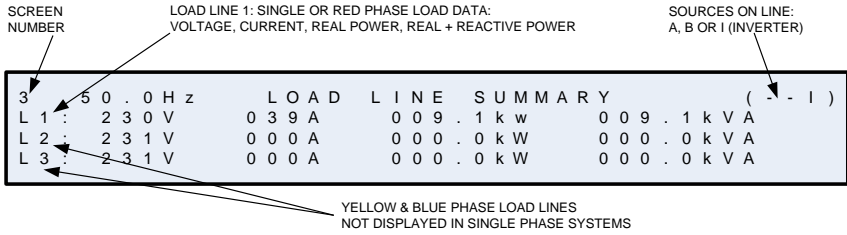

Figure 8: Screen 3 - Load Line Summary

The Load Line Summary screen shows the Load Voltage, Current, Real and Apparent Power Consumed.

L1, L2 or L3 abbreviates “Line 1, 2 or 3” and refers to the parameters associated with the AC line or module connected to the system. A 12 KVA MPC system for example would have 2 x 6 KVA modules and would display the rows L1 and L2 that refer to the 1st and 2nd inverter module stacked underneath the controller box. For 3 phase systems phases are labeled L1 to L3 and each inverter module gets assigned a separate phase.

3.4 Source Line Summary

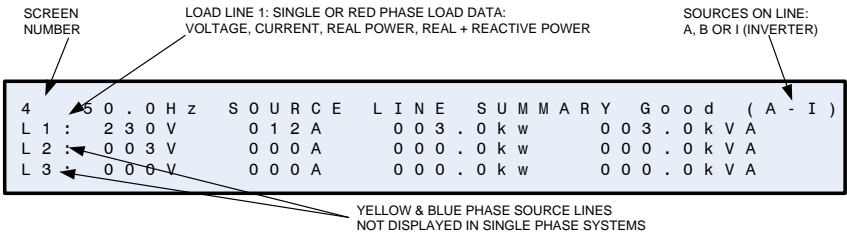

Figure 9: Screen 4 – Source Line Summary

The Source Line Summary screen shows the Load Voltage, Current, Real and Apparent Power Consumed.

3.5 Source Status Screen

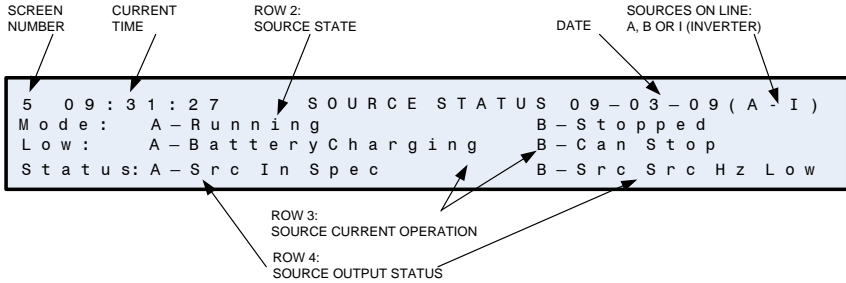

Figure 10: Screen 5 – Source Status

NOTES: If a Source is disabled, the data for that Source will not be displayed.
To disable a Source, set MENU → SYSTEM CONFIG/SETUP → SYSTEM SETUP → SOURCE → SP16 (Source A) or SP17 (Source B) to NONE.

Row 2: Typical Source States are Running, Stopped, Cooling Down, etc.

Row 3: Gives the reason why the source is still required. Manually controlled generators can be stopped if “Can Stop” is displayed. Note that source current operations are listed under “Why does the Generator not stop when it should” on page 61.

Row 4: If there is more than one fault with the source output the display will show each fault in turn at one second intervals. For example, if a Source is stopped the faults displayed will be Src Line V Low (Source Line Volts Low) and Src Hz Low (Source Frequency Low).

3.6 Inverter Line Summary

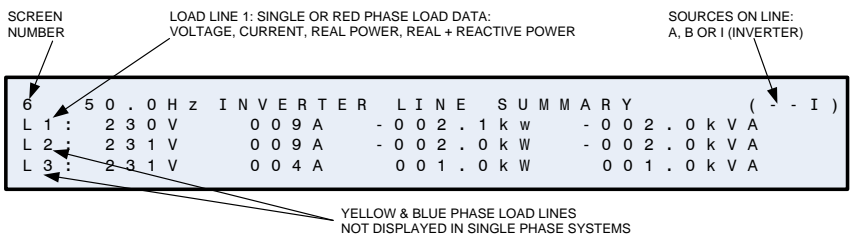

Figure 11: Screen 6: Inverter Line Summary

The Source Line Summary screen shows the Load Voltage, Current, Real and Apparent Power Consumed. Note that – before a reading indicates to the inverter.

3.7 DC Summary Screen

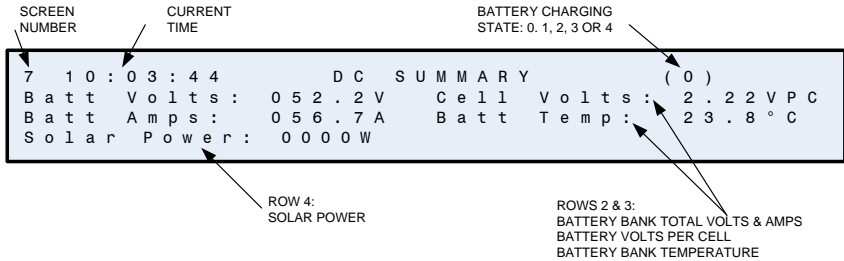

Figure 12: Screen 7 – DC Summary

3.8 Battery Status Screen

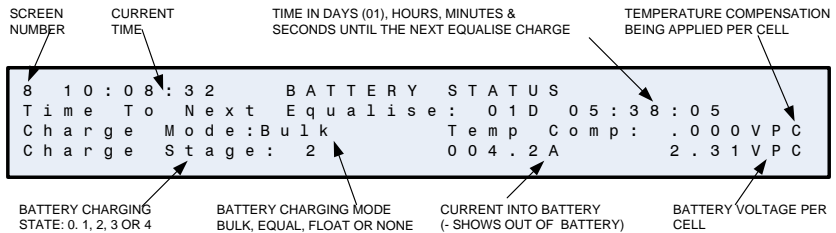

Figure 13: Screen 8 - Battery Status

For further information on equalising and temperature compensation see Equalisation on page 47 and Temperature Compensation on page 48.

3.9 Solar Status Screen

SCREEN NUMBER CURRENT TIME IDENTIFIES WHAT THE SOLAR SYSTEM IS DOING SOLAR DUTY CYCLE (SEE BELOW)

```

9 10:08:32 SOLAR STATUS 09-03-09
Solar Mode: Charging
Duty Cycle: 000%
Volts: 048.0V Amps: 00.0A Power: 0000W

```

MPPT REGULATOR FITTED SHOWS PANEL VOLTAGE OTHERWISE SHOWS BATTERY VOLTAGE CURRENT BEING DELIVERED BY THE SOLAR SYSTEM POWER BEING DELIVERED BY THE SOLAR SYSTEM

DUTY CYCLE IS APPLICABLE ONLY TO BUILT IN MPPT REGULATORS, AND SHOWS THE RATIO OF OUTPUT (BATTERY) TO INPUT (SOLAR) VOLTAGE. E.G. AT 100%, THE INPUT AND OUTPUT VOLTAGES WILL BE THE SAME, BUT AT 50%, THE OUTPUT WILL BE HALF OF THE INPUT VOLTAGE

Figure 14: Screen 9 – Solar Status

3.9.1 Current delivered by the Solar (PV) panels

Duty cycle. On systems that do not have a built in MPPT regulator the duty cycle will be 100% most of the time. If it is less then there is excess solar power available and not all of it is being utilized.

3.10 Smart Loads

SCREEN NUMBER CURRENT TIME

```

10 10:08:32 SMART LOADS 09-03-09
SMART LOAD 1: ON
SMART LOAD 2: OFF

```

IF THE IO EXTENDER CARD OPTION IS INSTALLED THE SMART LOAD RELAY INSIDE THE INVERTER CAN BE CONFIGURED TO SHED LOADS AT SPECIFIC TIMES, AND EVENTS. THIS SCREEN SHOWS WHETHER THE SMART LOADS CONFIGURED ARE ON OR OFF. IF NO SMART LOADS HAVE BEEN SETUP A CORRESPONDING MESSAGE IS DISPLAYED ON THE SCREEN

Figure 15: Screen 10 – Smart Loads

See Smart Load Relay on page 59 for further information.

3.11 Summation Logs

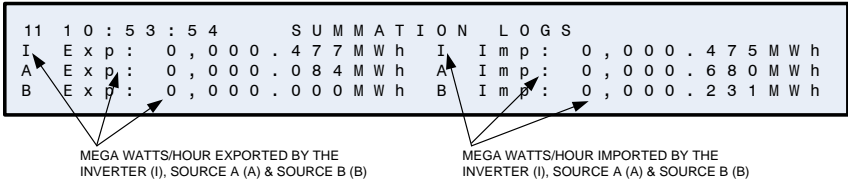

Figure 16: Screen 11 – Summation Logs

3.12 Run Hours and Site Logs

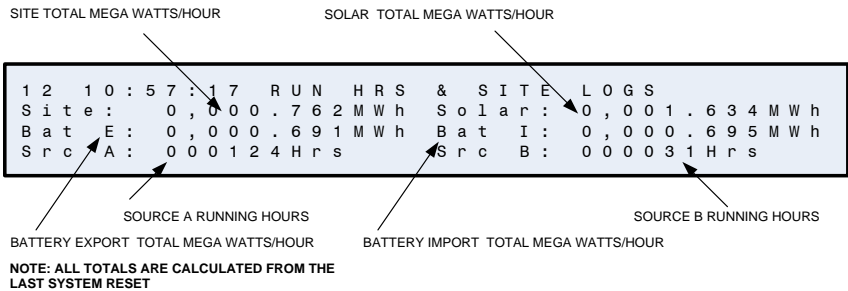

Figure 17: Screen 12 – Run Hours and Site Logs

3.13 Miscellaneous Logs

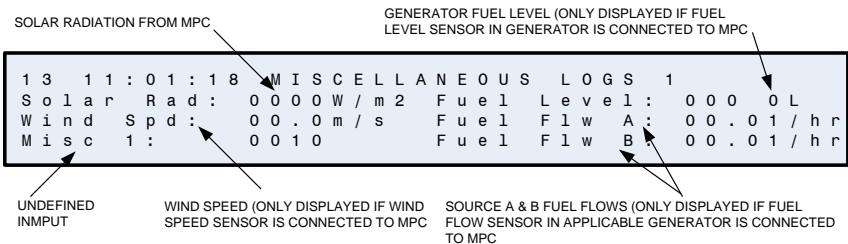

Figure 18: Screen 13 – Miscellaneous Logs

3.14 Temperatures

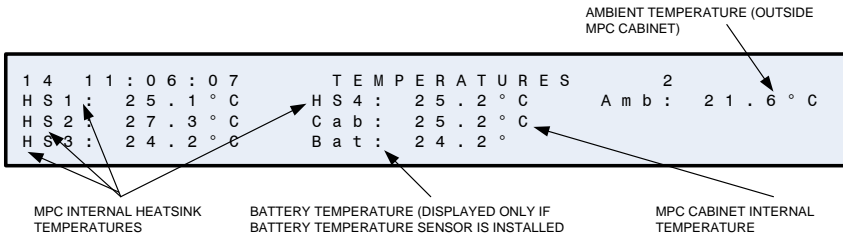

Figure 19: Screen 14 – Temperatures

3.15 System Information

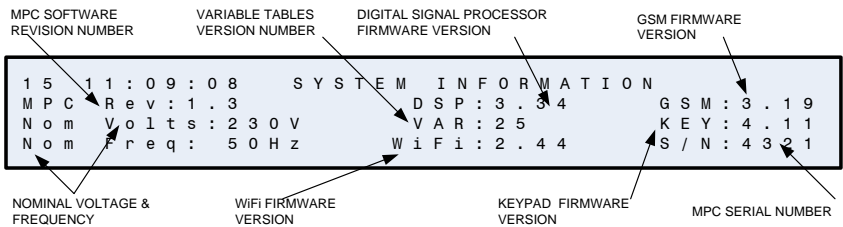

Figure 20: Screen 15 – System Information

Note that the WIFI and GSM fields will only show a firmware version (other than 0.00) if the optional communications package is installed.

4. Connecting External Sources

4.1 General

Generally external sources will be connected and setup at the time of the installation. It may be, however, that a standby generator is required due to for example, grid supply problems. Another possibility is that your load has increased and the source generator you are using cannot cope and must be replaced by a higher capacity model.

4.2 Types of Generator

Both manual and electric start generators can be used. If an electric start generator is installed, the MPC can control its operation, switching it on and off as required.

The better the quality of the generator that you install, the less the likelihood there is of problems occurring after installation. Trouble Shooting on page 43 contains a section on trouble shooting generator installation.

4.3 Preparation

Before starting the installation ensure that you read the owner's handbook for the generator that you are installing and you are fully aware of requirements such as cable size and generator siting information.

Use shielded PVC wire (60A -10 mm³) per AC Input (each module) and Output Live and Neutral connections on this MPC system.

4.4 Installing a Generator

- 1) Power down MPC (see page 15).
- 2) If MPC is connected to grid, select Bypass Mode on Bypass Box (see page 17).
- 3) Switch OFF and isolate any connected generators.
- 4) Remove Battery Fuse.
- 5) If Solar Array is fitted remove Solar Array Fuse.
- 6) Wait for approximately 20 to 30 seconds for the internal capacitors to discharge completely before resuming.
- 7) Remove left side panels from each Inverter Module to access the AC Input and Output terminals.
- 8) Connect Generator to Source A or Source B input connections on the Inverter Modules noting the following:

NOTE: EARTHS MUST BE CONNECTED IN ALL INSTALLATIONS.

- a) Single phase with single inverter module (Refer Figure 21).

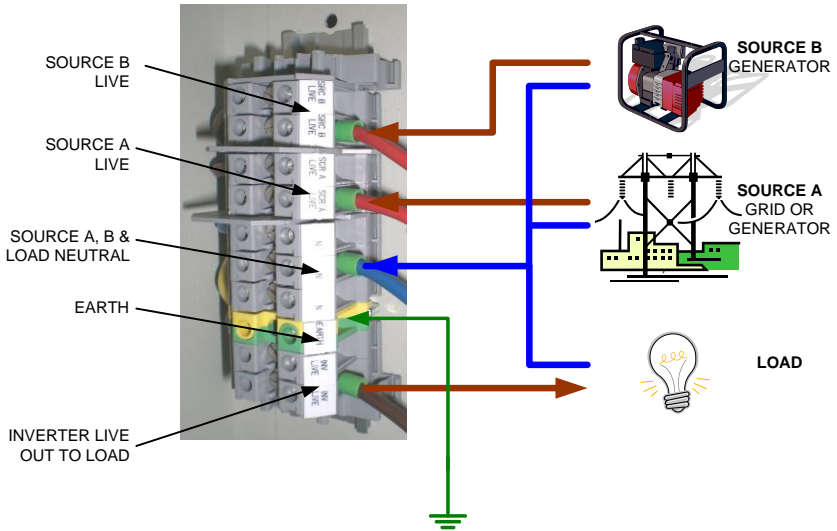

Figure 21: Single Phase AC Input/Output Connections for One Inverter Module

- b)** Single phase with multiple inverter modules (see Figure 22). A single phase system can have a maximum of three Inverter Modules connected in parallel. If two inverter modules are installed use the lower module as the input/output module. If three inverter modules are installed use the middle module as the input/output module.

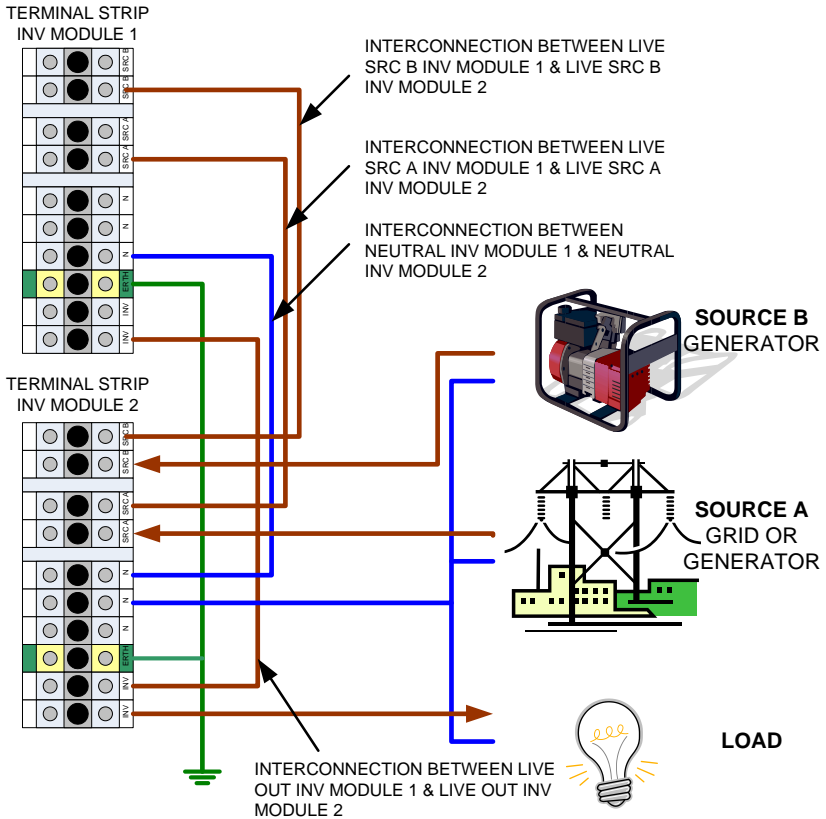

Figure 22: Single Phase AC Input/Output Connections for Multiple Inverter Modules

- c) Three phase installation which will always have three Inverter Modules, i.e. one for each phase (see Figure 23). If both Source A and Source B inputs are used correct phases are connected to each Inverter Module. Top module = Red Phase, Middle Module = Yellow Phase and Bottom Module = Blue Phase. Earth and Neutral must be connected.

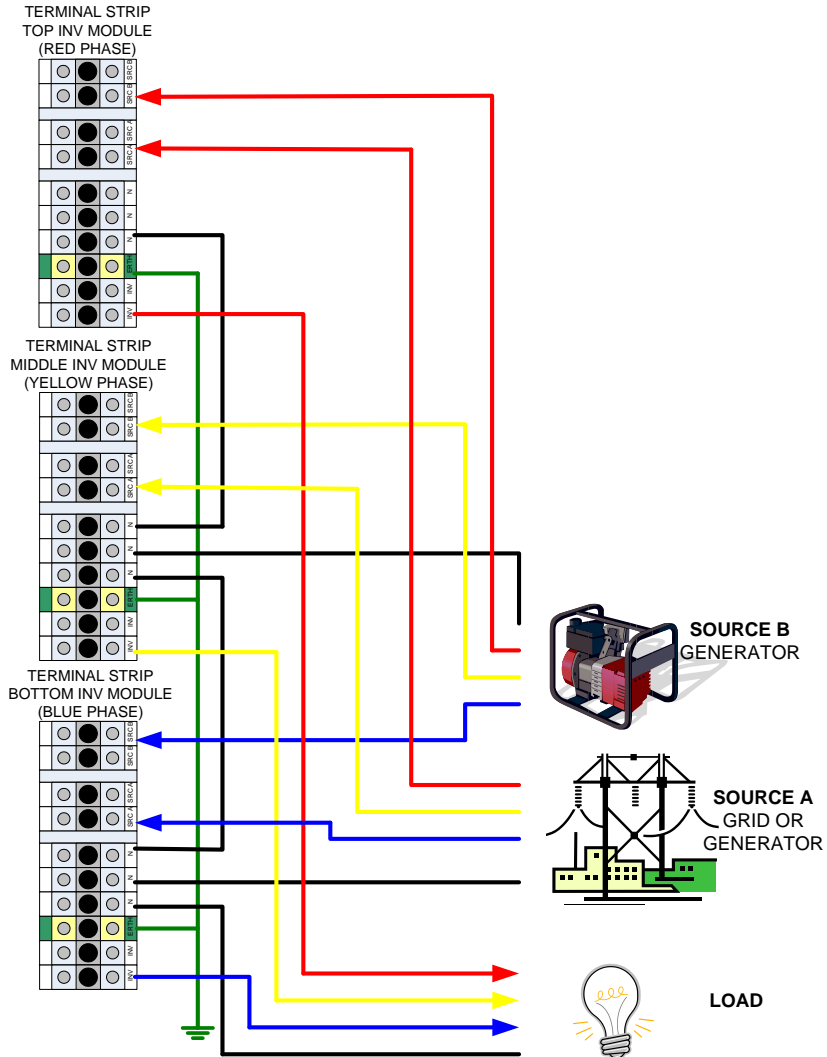

Figure 23: 3-Phase AC Input/Output Connections

- 9) If Generator is to be controlled by MPC connect Electric Start on the Generator to Generator Start Output on rear panel or the optional IO Extender Interface of Control Box.
- 10) Refit side panels to Inverter Module(s).
- 11) Check Generator(s) are set for required operation.
- 12) Replace Battery Fuse and if applicable Solar Array Fuse.

- 13) Power up MPC (see page 15).
- 14) If MPC is connected to grid, set Normal Mode on Bypass Box (see page 17).

Configure Generator operations as required (see

- 15) Table 2 on page 20 for a complete list of source configuration options). Note that the following Must be set:

| SP | Name | Meaning | Default Setting |
|-----|-------------------|---|-----------------|
| 012 | Source A Size | Set the size (kVA) of Source A | Default 8 kVA |
| 013 | Source B Size | Set the size (kVA) of Source B | |
| 016 | Source A Type | Set what Source A is: Utility (UTIL), Generator (GEN) or no source fitted (NONE) | |
| 017 | Source B Type | Set what Source B is: Utility (UTIL), Generator (GEN) or no source fitted (NONE) | Default UTIL |
| 023 | Generator Control | Must be set only if both sources are generators: EQUAL means both generators are of equal importance, BACK A means Source A is the backup generator. BACK B means Source B is the backup generator. | EQUAL |

5. About Batteries

5.1 General

A number of lead acid batteries are used together to form the battery bank for the MPC. Basically there are two types of lead acid that can be used as follows:

- “Standard, Gel, Sealed or Low Maintenance” battery which is another name for a normal car battery. This type of battery is designed to provide a large current for a very short period of time. They are not designed to be regularly discharged by more than 25% of their capacity. This battery is suitable for backup applications.
- “Deep cycle” lead acid batteries are designed to be repeatedly discharged to at least 50% of their capacity, which makes them suitable for homes using solar power or off-grid power use.

Thus if in your application you are repeatedly charging and discharging your batteries you should be using deep cycle batteries. If, however, you are using your system as a UPS low maintenance batteries may be sufficient. Standard batteries can be flooded batteries which require regular maintenance or sealed which are maintenance free. Deep cycle batteries are available only in the flooded

variety. If standard batteries are suitable maintenance free type should be selected as they do not require topping up of their electrolyte during their life.

Your MPC will have either a 36 or 48 volt battery bank while the number batteries will depend on the capacity required. Batteries will be connected in series to give the required 36 or 48 volts. Further strings of batteries may be connected in parallel with the first group to increase the capacity of the battery bank.

5.2 Battery Bank Location

The person who installed your MPC system will have installed the battery bank in a suitable and safe location. If, however, you ever consider moving the battery bank position the following should be considered:

- Batteries MUST be installed in a well ventilated environment away from sunlight
- Ensure that the battery leads are as short as possible for maximum efficiency
- A Battery Fuse MUST ALWAYS be installed and be as close as possible to the batteries!
- ALWAYS observe the electrical wire colour coding convention i.e. connect red wire to POSITIVE, and the black wire to NEGATIVE
- Batteries should be mounted on stands to keep them clear of the ground. If the batteries are ground mounted they should be thermally insulated from the ground temperature.

5.3 Maintenance

Battery maintenance required will be detailed in the documentation supplied with the battery and for flooded batteries generally includes checking of the electrolyte levels on a regular basis and topping up with distilled water when necessary. Flooded batteries also require equalizing which is an overcharge performed on lead-acid batteries after they have been fully charged (see Equalisation on page 47).

Maintenance free, sealed or “gel” batteries MUST NOT be equalised.

Providing it is maintained and sited correctly, a good quality battery should last at least 3 year’s continuous use before needing replacement.

5.3.1 Equalisation

Individual batteries and individual cells within lead acid batteries react differently to being charged. Over time battery performance will drop as differences become more pronounced. Because of this it is necessary to perform an equalization charge at least once per month.

In the MPC menus there are four settings applicable to equalization:

SP072 Battery Equalisation Cell Volts which is used to set equalising charge voltage (default setting 2.4 volts per cell).

SP073 Battery Equalisation Time Interval which is the time period between equalising charges and by default is set to 744 hours (31 days).

SP074 Battery Equalisation Charge Period which is the maximum time that the equalizing charge is applied for (default setting 2 hours).

SP077 Battery Equalisation Enabled which is set to YES for flooded batteries and NO for sealed batteries (default setting NO).

Note that the default settings are typical settings and if necessary should be changed in accordance with the battery manufacturer's instructions.



CAUTION: An equalization charge **MUST ONLY** be performed on vented (not sealed) flooded lead acid batteries.

5.3.2 Temperature Compensation

Lead acid battery performance is temperature dependent in that the available capacity and maximum current both change from low temperature to raised temperatures. To optimise performance over a wide temperature range, MPC menu options allow the following to be set:

SP86 and SP87 Zero Compensation Upper Temp and Zero Compensation Lower Temp. Between these two temperatures to temperature compensation to the battery charging voltage is applied.

SP84 Upper Temp Compensation which is the temperature compensation voltage applied per degree centigrade for temperatures above the zero compensation upper temperature (default setting 5.5 mV/°C).

SP85 Lower Temp Compensation which is the temperature compensation voltage applied per degree centigrade for temperatures below the zero compensation lower temperature (default setting 5.5 mV/°C).

SP88 Min Compensation Upper Temp which is the maximum temperature at which the temperature compensation applied will change for an increase in temperature (default setting 50°C). This means that the compensation applied at 51°C will be the same as that applied at 50°).

SP89 Min Compensation Lower Temp which is the minimum temperature at which the temperature compensation applied will change for a decrease in temperature (default setting 1°C). This means that the compensation applied at 0°C will be the same as that applied at 1°).

The charging voltage needs to be raised as temperature falls to ensure that the battery continues to accept charge. Similarly, at higher temperature, the charging voltage needs to be reduced to prevent excessive gassing due to overcharge.

Overcharge consumes electrolyte and can dramatically reduce the life of some types of battery, in particular recombinant types (so called sealed batteries).

5.4 Replacing a Battery

Always replace a battery with a battery of the same type and capacity. Never replace a flooded battery with a maintenance free battery or vice-versa. If you not sure about the type and capacity of the batteries installed refer to the System Configuration guide on page 10.

To replace a battery:

- 1) Power down MPC (see page 15).
- 2) If MPC is connected to grid, select Bypass Mode on Bypass Box (see page 17).
- 3) Switch OFF and isolate any connected generators.
- 4) Remove Battery Fuse.
- 5) If Solar Array is fitted remove Solar Array Fuse.
- 6) Taking care not to short circuit the battery terminals, disconnect and remove the faulty battery.

NOTE: To prevent short circuits we recommend that you always use an insulated spanner when connecting or disconnecting individual batteries or battery banks (see Figure 24 below).



Figure 24: Danger of Short Circuits when using an Un-insulated Spanner to Connect/Disconnect Batteries

- 7) Place new battery in position and connect and tighten positive and negative connections (red positive, black negative).
- 8) Repeat steps 6 and 7 for any other batteries that need replacing.
- 9) Replace Battery Fuse and if applicable Solar Array Fuse.
- 10) Power up MPC (see page 15).
- 11) If MPC is connected to grid, set Normal Mode on Bypass Box (see page 17).

Configure Batteries as required (see Battery Charging Examples on page 51 and

- 12) Table 4 on page 28 for a complete list of battery configuration options). Note that the following Must be set:

| SP | Name | Meaning | Default Setting |
|-----|-----------------------------|---|-----------------|
| 070 | Batt Float Cell Volts | The float charge voltage level for the system battery bank. For flooded lead acid batteries typically use 2.30 VPC (volts per nominal 2.00 volt cell) For sealed batteries typically use 2.20 VPC | 2.14 VPC |
| 071 | Batt Bulk Cell Chg Volts | The voltage level that the batteries must achieve during Battery Charge Stage 2. For flooded lead acid batteries typically use 2.35 VPC (volts per nominal 2.00 volt cell) | 2.35 VPC |

| | | | |
|-----|------------------------|--|----------|
| | | For sealed batteries typically use 2.30 VPC | |
| 072 | Batt Equ Cell Volts | This setting defines the equalisation voltage level of the battery bank. MUST BE SET FOR FLOODED BATTERIES ONLY. IF SEALED BATTERIES ARE USED SP077 MUST BE SET TO NO | 2.40 VPC |
| 077 | Equ Enabled | If this set point is enabled, the control system will periodically attempt to equalise the batteries to the equalisation cell voltage. SET TO NO FOR SEALED BATTERIES YES FOR FLOODED BATTERIES | NO |

5.5 Battery Charging Examples

All the examples given below refer to batteries that are supplied by MLT Drives.

5.5.1 Example 1

MPC and Battery Type

You have a MLT PowerStar 6 KVA, 48V Inverter. The battery cell used is a FNB Solar M Cell Type MTE25S. There are 24 x 2 V cells connected in series to make the required 48V battery. From the extract of the table below the capacity at the 5 hour discharge rate is 1188 Ah and 1660 Ah at 100 hour discharge rate.

| Type | Ah | Ah | Peukert |
|-------|------|------|---------|
| | C5 | C100 | k |
| MIL15 | 378 | 530 | 1.13 |
| MIL17 | 432 | 600 | 1.12 |
| MIL21 | 540 | 750 | 1.12 |
| MIL25 | 648 | 900 | 1.12 |
| MTL25 | 756 | 1050 | 1.12 |
| MTE21 | 990 | 1380 | 1.12 |
| MTE25 | 1188 | 1660 | 1.13 |
| MTE29 | 1386 | 1956 | 1.13 |

Capacity and Peukert Factor

The default settings for both the Battery Capacity (at the 5 hour discharge rate C5) and the Peukert Factor must be changed to the values given in the above Table.

Battery Charging Float and Bulk Stage Voltages

FNB Solar M Cell are flooded lead acid batteries which are not maintenance free and should be 'gassed' periodically to prevent sulfation. To achieve this both the Battery Float Cell Charging Voltage and the Battery Bulk Cell Charging Voltage must be as specified in the battery data sheet. In this case only the Battery Bulk Cell Charging Voltage must be increased from the default settings.

Equalisation

Deep cycle flooded lead acid batteries need to be equalised periodically. To configure this Equalise Enabled must be set to YES and the Battery Equalise Charge Period set to 4 hours.

NOTE: For small size batteries (Type MIL15, 17) leave the Battery Equalise Charge Period to 2 hours.
For medium size batteries (Type MIL21 to 25) set Battery Equalise Charge Period to 3 hrs.

Maximum Battery Charging Current

The battery shunt size in a 6 kVA MPC is 100A. If the battery capacity at the 5 hour discharge rate is 1188 Ah then the Maximum Battery Charging Current is 10% of 1188 which is 118A. If the Maximum Battery Charging Current is set 100% the inverter can charge the batteries at a current of up to 100A which is a little lower than the maximum DC charge rate of the MTE25 battery bank.

NOTE: The Maximum DC Charge Rate is dependent on the kVA of the system and the DC voltage and is given in MPC Specification Sheet. Typical values are:

| Maximum DC Charge Rate | | | | | | |
|------------------------|------|------|------|------|------|------|
| Inverter kVA | 6 | 12 | 18 | 8 | 16 | 24 |
| 48V Systems | 100A | 200A | 300A | 130A | 260A | 390A |
| 36V Systems | 150A | 300A | 450A | - | - | - |

To enable a Maximum DC Charge Rate of 100A you should increase the Maximum Battery Charging Current from 50% default setting to 100%.

If you have alternative source charging the batteries too (i.e. Solar PV) then you do not necessarily need to increase the Maximum Inverter AC Charge rate (Inv Chrg Max, Setting 130). If only source power is used to charge you batteries then increase the maximum inverter AC charge rate to 80%.

6 kVA or 6000W divided by 48V = 125 A

100A divided 125A x 100% = 80%

Maximum Inverter Charge Rate = 80%

Changes to Battery Settings

| Set Point | Parameter | Default | New |
|-----------|---------------------------------|----------|---------|
| 068 | Battery Capacity | 0600 Ah | 1188 Ah |
| 069 | Battery Peukert Factor | 1.21 | 1.13 |
| 070 | Batt Float Cell Volts | 2.14VPC | 2.25VPC |
| 071 | Batt Bulk Cell Chg Volts | 2.35VPC | 2.40VPC |
| 072 | Batt Equ Cell Volts | 2.40VPC | 2.50VPC |
| 073 | Batt Equ Time Interval | 744hrs | |
| 074 | Batt Equ Chg Period | 2hr | 4hr |
| 075 | Batt Bulk Chg Period | 2hr | |
| 076 | Batt Min Bulk Chg | 10% | |
| 077 | Equ Enabled | NO | YES |
| 079 | Batt Min Equ Chg | 5% | |
| 084 | Upper Temp Compnsatn | 5.5mV/C | |
| 085 | Lower Temp Compnsatn | 5.5mV/C | |
| 086 | Zero Compnsatn Upper temp | 30C | |
| 087 | Zero Compnsatn Lower temp | 2C | |
| 088 | Min Compnsatn Upper Temp | 50C | |
| 089 | Min Compnsatn Lower Temp | 1C | |
| 090 | Max Batt Chg Amps | 50% | 100% |
| 091 | DC Recon Volts | 2.250VPC | |
| 092 | DC High Shutdown Volts | 2.600VPC | |
| 093 | DC Low Shutdown Volts C1 | 1.700VPC | |
| 094 | DC Low Shutdown Volts C5 | 1.800VPC | |
| 095 | DC Low Shutdown Volts C10 | 1.850VPC | |
| 096 | Batt Overtemp Shutdown | 48°C | |
| 133 | Blk Chg Start Time | 00h00m | |

5.5.2 Example 2:

MPC and Battery Type

You have a MLT PowerStar 18 KVA, 36V Inverter. The battery comprises 10 strings of Trojan T-1056V - 185 Ah (at 5 hour discharge rate) batteries. As a Trojan T-1056V battery has a 6V nominal terminal voltage there are 6 batteries in each string to provide the required 36 V nominal voltage. As there are 10 strings there are 60 batteries in total.

Capacity and Peukert Factor

The Battery Capacity is the capacity of each battery times the number of paralleled strings, i.e. 185 Ah x 10 strings = 1850 Ah.

The Peukert Factor also changes in accordance with the Battery Data Sheet.

Battery Charging Float and Bulk Stage Voltages

Trojan T-1056V batteries are flooded lead acid batteries which are not maintenance free and should be 'gassed' periodically to prevent sulfation. To achieve this both the Battery Float Cell Charging Voltage and the Battery Bulk Cell Charging Voltage must be as specified in the battery data sheet. In this case no changes are required to these two settings.

Equalisation

Deep cycle flooded lead acid batteries need to be equalised periodically. To configure this Equalise Enabled must be set to YES and the Battery Equalise Charge Period set to 4 hours.

Maximum Battery Charging Current

The Maximum Battery Charging Current is 10% of the nominal Ah capacity = 185A. Maximum DC Charge Rate for an 18 KVA 36V System = 450A.

$$185 \text{ Ah divided } 450 \text{ A} \times 100\% = 41\%$$

$$\text{Maximum Battery Charging Current} = 41\%$$

If you have alternative source charging the batteries too (i.e. Solar PV) then you do not necessarily need to increase the Maximum Inverter Charge. Otherwise to enable a Maximum DC Charge Rate of 185A from the source you should increase the Maximum Inverter AC Charge rate (Inv Chrg Max, Setting 130) from 20% default setting to 37%:

$$18 \text{ kVA or } 18000\text{W divided by } 36\text{V} = 500 \text{ A}$$

$$185 \text{ Ah divided } 500\text{A} \times 100\% = 37\%$$

$$\text{Maximum Battery Charging Current} = 37\%$$

Your battery settings should be as listed below:

| Set Point | Parameter | Default | New |
|-----------|-------------------------------|---------|----------|
| 068 | Battery Capacity | 0600 Ah | 1850 Ah |
| 069 | Battery Peukert Factor | 1.21 | 1.15 |
| 070 | Batt Float Cell Volts | 2.14VPC | 2.25 VPC |
| 071 | Batt Bulk Cell Chg Volts | 2.35VPC | |
| 072 | Batt Equ Cell Volts | 2.40VPC | |
| 073 | Batt Equ Time Interval | 744hrs | |
| 074 | Batt Equ Chg Period | 2hr | 4hr |
| 075 | Batt Bulk Chg Period | 2hr | |
| 076 | Batt Min Bulk Chg | 10% | |
| 077 | Equ Enabled | NO | YES |
| 079 | Batt Min Equ Chg | 5% | |

| Set Point | Parameter | Default | New |
|-----------|---------------------------|----------|-----|
| 084 | Upper Temp Compnsatn | 5.5mV/C | |
| 085 | Lower Temp Compnsatn | 5.5mV/C | |
| 086 | Zero Compnsatn Upper temp | 30C | |
| 087 | Zero Compnsatn Lower temp | 2C | |
| 088 | Min Compnsatn Upper Temp | 50C | |
| 089 | Min Compnsatn Lower Temp | 1C | |
| 090 | Max Batt Chg Amps | 20% | 41% |
| 091 | DC Recon Volts | 2.250VPC | |
| 092 | DC High Shutdown Volts | 2.600VPC | |
| 093 | DC Low Shutdown Volts C1 | 1.700VPC | |
| 094 | DC Low Shutdown Volts C5 | 1.800VPC | |
| 095 | DC Low Shutdown Volts C10 | 1.850VPC | |
| 096 | Batt Overtemp Shutdown | 48°C | |
| 133 | Blk Chg Start Time | 00h00m | |

5.5.3 Example 3

MPC and Battery Type

You have a MLT PowerStar 4 KVA MLT 48V Inverter. The battery comprises 2 strings of Delkor GP31 - 102 Ah (at 20 hour discharge rate) batteries. As a Delkor GP31 battery has a 12 V nominal terminal voltage there are 4 batteries in each string to provide the required 48 V nominal voltage. As there are 2 strings there are 8 batteries in total.

The Delkor GP31 is a sealed lead acid battery with the following properties:

Capacity at 20 hour discharge rate (C20) = 102 Ah

Capacity at 5 hour discharge rate (C5) = 85 Ah

Peukert Factor = 1.15

Capacity and Peukert Factor

Total capacity (C5) of the system (2 strings) = $85 \times 2 = 170$ Ah

Battery Charging Float and Bulk Stage Voltages

Check both the Battery Float Cell Charging Voltage and the Battery Bulk Cell Charging Voltage must be as specified in the battery data sheet. In this case only the Battery Float Cell Voltage need be changed.

Equalisation

The Delkor GP31 is a Sealed Lead Acid Battery - **Do not Equalise**. Ensure Equalise Enable is left set to NO.

Maximum Battery Charging Current

The battery shunt size in a 4 kVA MPC is 80A. If the battery capacity at the 5 hour discharge rate is 170 Ah then the Maximum Battery Charging Current is 10% of 170 which is 17A.

17A divided by 80A x 100% = 21.5% Maximum Battery Charge Amps

Thus the default Maximum Battery Charging Current (50%) should be reduced.

Your battery settings should be as listed below:

| Set Point | Parameter | Default | New |
|-----------|-------------------------------|----------|-------|
| 068 | Battery Capacity | 0600 Ah | 170Ah |
| 069 | Battery Peukert Factor | 1.21 | 1.15 |
| 070 | Batt Float Cell Volts | 2.14VPC | 2.20 |
| 071 | Batt Bulk Cell Chg Volts | 2.35VPC | |
| 072 | Batt Equ Cell Volts | 2.40VPC | |
| 073 | Batt Equ Time Interval | 744hrs | |
| 074 | Batt Equ Chg Period | 2hr | |
| 075 | Batt Bulk Chg Period | 2hr | |
| 076 | Batt Min Bulk Chg | 10% | |
| 077 | Equ Enabled | NO | |
| 079 | Batt Min Equ Chg | 5% | |
| 084 | Upper Temp Compnsatn | 5.5mV/C | |
| 085 | Lower Temp Compnsatn | 5.5mV/C | |
| 086 | Zero Compnsatn Upper temp | 30C | |
| 087 | Zero Compnsatn Lower temp | 2C | |
| 088 | Min Compnsatn Upper Temp | 50C | |
| 089 | Min Compnsatn Lower Temp | 1C | |
| 090 | Max Batt Chg Amps | 50% | 20% |
| 091 | DC Recon Volts | 2.250VPC | |
| 092 | DC High Shutdown Volts | 2.600VPC | |
| 093 | DC Low Shutdown Volts C1 | 1.700VPC | |
| 094 | DC Low Shutdown Volts C5 | 1.800VPC | |
| 095 | DC Low Shutdown Volts C10 | 1.850VPC | |
| 096 | Batt Overtemp Shutdown | 48°C | |
| 133 | Blk Chg Start Time | 00h00m | |

The electrolyte level of sealed lead acid batteries does not need to be checked.

6. About Solar Panels

6.1 Introduction

The term solar panel refers to a panel comprising a number of Photovoltaic (PV) cells which convert sunlight into electricity. The PV cells in a panel are connected together to form a usable size and electricity output.

Solar panels are a source of renewable energy which is becoming increasingly accessible.

As with most renewable systems solar panels are unable to provide energy at all times as there may be insufficient sunlight available. To fill the gaps, electricity can be supplied from storage batteries or generators in stand-alone systems or from the electricity grid in grid connected systems.

6.2 Connecting a Solar System to the MPC

An optional extra available with the MPC is the MPPT Regulator which controls the solar panels. MPPT is an acronym for Maximum Power Point Tracking. This applies to solar regulators which are DC-DC converters that allow the voltage of the solar panels to be different to the battery voltage. MPPT Regulators will then control the voltage of the solar panels to find the point where the most power is obtained from them. The point where maximum power is obtained differs between different types and makes of solar panels, and a graph of panel volts versus amps can usually be found in the data sheet of your panel.

If you are considering adding a solar system to your installation contact MLT or the person who installed your system for further details on the MPPT Regulator and its installation.

It is important to understand that that if you decide NOT to install the MPPT or other built-in Linear Regulator an external solar regulator MUST be used if you want to connect solar panels to your system.

Figure 2 on page 13 shows a system with the MPPT Regulator installed and identifies the solar panel connection points.



CAUTION: DO NOT connect solar panels directly to the solar input on a MPC that does not have a built in MPPT or solar linear regulator.

6.3 Configuring the Solar System

Once you have installed your solar system it must be configured. There is only one parameter that must be set which is SP”

Access MENU → SYSTEM SETUP/CONFIG → SYSTEM SETUP → SOLAR → 097 Solar Control.

The options available are: OFF, REG, MPPT H, MPPT S, MPPT H+S. Their meaning is as follows:

OFF – Use this option if a MPPT regulator is installed but not required. Note that if a MPPT regulator is not installed then the MPC will not measure any solar input.

REG – Use this option if an external or internal linear solar regulator is used. The output of the solar regulator is connected to the solar input on the rear panel of the MPC, which will measure the power is coming from the solar panels, and display it on the Solar Status screen (see page 39).

NOTE: The following settings apply only to systems with the optional MPPT Regulator installed.

MPPT H – This option uses a method known as “hill climbing” to find the maximum power point of your solar panels.

MPPT S – This option uses a method known as “sweeping” to find the maximum power point of solar panels. It operates by carrying out a periodic “sweep” where the regulator checks across the entire range of the solar panels output to find the optimum point. It then selects the optimum point and stays there until the next “sweep”. The Sweep Interval default is 10 minutes but can be adjusted if required using SP 100 Solar MPPT Sweep Interval.

MPPT H+S – This option uses a combination of both “hill climbing” and “sweeping”. It “sweeps” to find the initial maximum power point, and once there it uses hill climbing to ensure that it remains at the maximum power point for the full time until the next sweep.

6.4 Monitoring the Solar System Operation

If required you can use the SOLAR STATUS screen to monitor the solar system operation. Refer to Solar Status Screen on page 39 for the information displayed.

7. Smart Load Relay

7.1 Introduction

The Smart Load Relay option has three priority outputs which are available on the IO Extender Interface. The outputs are known as Priority 1, Priority 2 and Priority 3. Priority 1 has the highest priority and priority 3 the lowest.

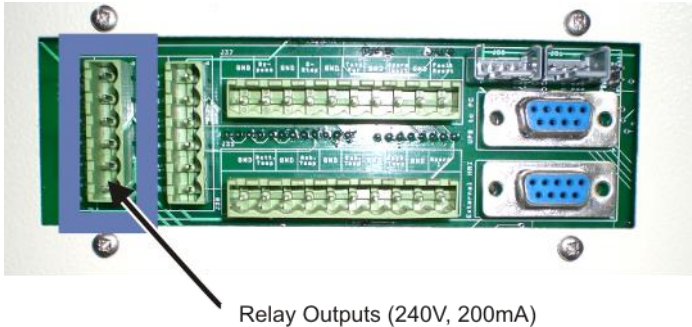

Relay Outputs (240V, 200mA)

Figure 25: Smart Load Relay Outputs on the IO Extender Interface

Before installation some planning is required to determine which loads are your most important and which are the least important. For example, the geyser could be least important, the stove the next most important while the fridge, computer, lights and TV are the most important. The electrician doing the installation would implement your requirements ensuring that the Priority 3 output controlled the geyser circuit, the Priority 2 output controlled the stove, air-conditioner and kettle circuits and the Priority 1 output controlled the fridge and TV circuits.



WARNING: The Smart Relay Option and the associated wiring should be installed by a qualified electrician. Failure to observe this precaution could result in bodily injury.

There are a number of thresholds that can cause the shedding or reconnection of a load. Each type of threshold can be disabled if not required. The threshold types are described in Configuration below.

In operation, the inverter monitors the turn 'ON' thresholds. If all of the set conditions are met, the inverter waits a set time (default 30 seconds) and if after this period, the condition is still met, closes a relay that can activate the next smart load. The inverter then returns to monitoring and the next time all turn 'ON' conditions are met, the inverter repeats the process and activates the next priority load. If after the set time, the condition is still met it will carry out the next action in the sequence. This process will be repeated a maximum of three times (or the number as set up by the No. of Smart Loads (SP141)). If any one of the

conditions can not be met and have exceeded the turn 'OFF' setting then the lowest priority load is shed. If the turn off condition is still exceeded the next load is removed until no more smart-loads are active.

For example, say a system is operating with three smart loads with a wait time of 1 minute with battery Voltage Per Cell thresholds of 2.1 (turn ON) and 1.97 (turn OFF) set. If the battery VPC falls to 1.97 for a period of 1 minute, the inverter will shed the priority 3 load. If after two hours, the VPC again falls to 1.97 for the required period, the inverter will shed the priority 2 load. If the sequence repeats again, the priority 1 load will be shed.

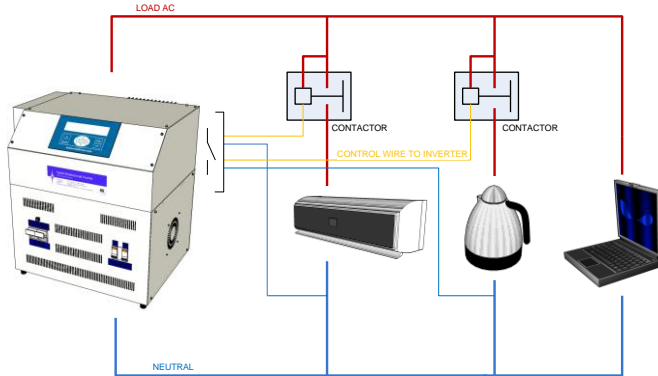

Figure 26: Smart Load Relay Outputs Example

7.2 Configuration

Depending on the requirement, not all of the smart loads may be required. The number of smart loads being used is set using SP141 Number of Smart Loads.

The Smart Load Relay Wait Time (SP142) is the time that a condition must be met before the next action in the sequence is carried out.

The thresholds that set when a load is shed and reconnected are listed below.

- Inverter Export Power – SP143 sets percentage of the inverter output at which the Smart Load is reconnected and SP144 and the percentage at which the load is shed.
- Battery Voltage – SP145 sets the Voltage Per Cell (VPC) at which the Smart Load is reconnected and SP146 the VPC at which it is shed.
- Battery Current – SP147 sets the percentage of battery discharge current at which the load is reconnected and SP148 the percentage of battery discharge current at which it is shed.

- Solar Current – SP149 sets the solar charge current at which the load will be reconnected and SP150 the solar charge current at which the load will be shed.
- Time-Of-Day Load Shedding - SP151 sets the time-of day when the load will be switched on and 152 the time of day when the load will be shed.

To disable any of the above criteria set both turn 'ON' and 'OFF' to zero. To disable the battery voltage threshold criteria set both 'ON' and 'OFF' to the same VPC level.

8. Trouble Shooting

8.1 Events and Faults

Both Events and Faults are shown on the main screen of the MPC:

- Most actions taken to control the inverter system cause an event message to be displayed on line 2 of the main display screen. Events are also recorded in the Event Log thus providing a system operation history.
- Faults are displayed on line 3 of the main display screen. With most faults the system in automatic mode will attempt to recover by clearing and re-trying the operation. If the system clears the fault, the fault message will clear after approximately 5 minutes automatically. If after four attempts the fault could not be cleared the system will mask the faulty peripheral and sound a 1 second interval 'beep – beep'. All faults are recorded in the Event Log.

8.2 Typical Problems

Why does the MPC not connect to a running generator?

Check that the generator is set up correctly and the MPC AC circuit breaker for the source is in the up position.

Did you start the generator manually? A source set up as generator must be controlled by the MPC and will not connect if started manually. Set up the source as a 'Utility' (SP016/017 set to UTIL) to start and stop the generator manually. Only use the 'Generator' (SP016/017 set to GEN) setting if the generator must be automatically started and stopped by the MPC. To force start a generator controlled by the MPC, access the FUNCTION menu and use RUN ANY GENERATOR, RUN GENERATOR A or RUN GENERATOR B as applicable. To stop a generator, use either TOGGLE ISOLATE SOURCE A or TOGGLE ISOLATE SOURCE B functions.

The output frequency of the generator is out of tolerance. With budget priced generators, the output frequency may increase with time. If it exceeds Source High Frequency Offset (default 3 Hz) then the generator will not connect. This can be checked by accessing screen 2 System Overview and monitoring line 2 (Src A/B). If the frequency displayed is .53.0 Hz it is out of tolerance. The solution is to increase applicable Source High Frequency Offset (maximum 10 Hz) ((MENU → System Config/Setup → System Setup → Source → 050 Src A High Freq Offset or 054 Src B High Freq Offset).

Why does the generator connect and then immediately drop out?

This could be caused by the distortion of the output waveform of the generator being outside of the Fault Tolerance envelope that has been setup. This fault generally occurs with budget priced generators. The solution is to increase the Source Fault Tolerance (MENU → System Config/Setup → System Setup → Source → 056 Src Fault Tolerance) until the generator stays connected.

Why does the Generator not stop when it should?

Access Menu → Screens → Source Status and check the display for a “stop” status message. Reasons sensed are:

- Can Stop - Self explanatory
- Generator Stop Average Period (Src Gen Stp Avg Period) - This means that all the Stop conditions are met, and the MPC will still run the generator until the Stop period has expired.
- Battery Charging - The battery is still charging
- Site Load P/P - The Load on the MPC is too high
- Inv Charge P/P - Usually only appears on 3 phase systems where the load in very unbalanced, the MPC might import on one or two phases and export on the others so that the generator sees a balanced load. If the import power on any phase is too high, then this will come up as a reason the generator cannot stop.
- Force Start - The generator was started after the user issued a Generator start command, and will not stop automatically
- Source Load - The Load on the generator is too high
- Minimum Up Time (Min Up Time) - The generator has not yet run for it's minimum run time
- If SP60 'Gen Start Time' was set up then the generator is used as a UPS backup and will run until the Utility comes back into range. Set this setting to zero to allow automatic generator stopping when the batteries are charged for example.

Why didn't I get the usual capacity from my storage batteries?

Were the batteries fully charged to start with? The batteries are subjected to a four stage charging cycle. , i.e. constant current (Batt Chg Stage 1), constant voltage (Batt Chg Stage 2), taper (Batt Chg Stage 3) and float voltage (Batt Chg Stage 4). To check what the charge state of the batteries was before they started discharging access the Event Browser (MENU → EVENT LOGS) and browse back through the events until the event indicating that the batteries were discharging which would be either Src A CB Opened or Src B CB Opened depending on which source is being used. Browse back from that event until the first battery charge event is displayed. If it is anything other than Batt Chg Stage 4 the batteries were not fully charged.

To ensure a consistent performance from the batteries it is important that they are charged your batteries correctly. Each battery type (flooded deep cycle, sealed, gel etc) has different charging requirements. Incorrect adjustment of battery settings is the most common cause of reduced backup time from your batteries. Refer to Battery Charging Examples on page for example configurations.

For Flooded Lead Acid Batteries it is important to check the battery electrolyte level periodically. Never leave the battery cells with the electrolyte below the required level.

One or more of the batteries in the battery bank is faulty. Check the batteries in accordance with the manufacturer's documentation and replace as necessary (see Temperature Compensation on page 48).

8.3 Fault Recovery

When a fault occurs:

- 1) Note the Fault Message on the display and refer to Table 9 below.
- 2) Identify the fault and carry out the required action. Note that if a Fault Reset is required refer to page 17 for further information.

Table 9: Fault Messages

| Fault Message Displayed | Description |
|-------------------------|-------------|
|-------------------------|-------------|

| Fault Message Displayed | Description |
|---|--|
| <p><i>Low Inv Volts L1</i> <i>Low Inv Volts L2</i> <i>Low Inv Volts L3</i></p> | <p>The inverter voltage on the phase is low and out of range.</p> <p>Reason: The fault could have been caused by the inverter voltage tolerance settings being narrower than the source voltage tolerance and the inverter was set up to track the source voltage.</p> <p>Action:</p> <ol style="list-style-type: none"> Increase your source low voltage setting Menu → System Config /Setup → System Setup → Source → 048 Src A Low Volts or 052 Src B Low Volts Contact Technical Support (see page 9) <p>Note: In automatic mode the inverter will restart 4 times in an attempt to clear this fault. If fault is not cleared inverter will shutdown.</p> |
| <p><i>High Inv Volts L1</i> <i>High Inv Volts L2</i> <i>High Inv Volts L3</i></p> | <p>The inverter voltage on this phase became high and out of range.</p> <p>Reason: The fault could have been caused by the inverter voltage tolerance settings being narrower than the source voltage tolerance and the inverter was set up to track the source voltage.</p> <p>Action:</p> <ol style="list-style-type: none"> Reduce your source high voltage tolerance. The inverter may not operate continuously at more than 12% of its nominal voltage rating. Setup/System Setup/Source/047 Src A High Volts or 051 Src B High Volts Contact Technical Support (see page 9) <p>Note: In automatic mode the inverter will restart 4 times in an attempt to clear this fault. If fault is not cleared the inverter will shutdown.</p> |
| <p><i>Sync L1 Fail</i> <i>Sync L2 Fail</i> <i>Sync L3 Fail</i></p> | <p>The inverter will synchronise to phase 1 or module 1 of the inverter.</p> <p>Reason: On three phase systems the other phases are displaced by 120 degrees. If a significant voltage is measured between the grid and the inverter voltage on any phase a sync error of the affected phase/module will be displayed and the inverter is immediately stopped.</p> <p>Action: Contact Technical Support (see page 9).</p> |
| <p><i>Inv Overload</i></p> | <p>Inverter Overload</p> <p>Reason: The load on the inverter exceeds the inverter rating. The inverter will have stopped to prevent overheating or damage to itself.</p> <p>Action:</p> <ol style="list-style-type: none"> Reduce Load and carry out Fault Reset Contact Technical Support (see page 9) <p>Note: In automatic mode the inverter will restart 4 times in an attempt to clear this fault. If fault is not cleared the inverter will shutdown.</p> |

| Fault Message Displayed | Description |
|---|--|
| <p><i>Inv Current Limit L1</i> <i>Inv Current Limit L2</i> <i>Inv Current Limit L3</i></p> | <p>The current on this line/phase on the inverter exceeded the maximum current of 200% peak.</p> <p>Reason: This fault will occur if you short circuit the output terminals of the inverter or the load is too high.</p> <p>Action:</p> <ol style="list-style-type: none"> Reduce Load or remove short circuit then carry out Fault Reset If the load is disconnected and the inverter still reports this fault then turn off the inverter or if a MOSFET fault is then reported contact technical support. Contact Technical Support (see page 9) <p>Note: In automatic mode the inverter will restart 4 times in an attempt to clear this fault. If fault is not cleared the inverter will shutdown.</p> |
| <p><i>MOSFET Error L1A</i> <i>MOSFET Error L2A</i> <i>MOSFET Error L3A</i> <i>MOSFET Error L1B</i> <i>MOSFET Error L2B</i> <i>MOSFET Error L3B</i></p> | <p>MOSFET failure</p> <p>Reason: The MOSFET block inside the inverter module has failed.</p> <p>Action:</p> <ol style="list-style-type: none"> Carry out Fault Reset Contact Technical Support (see page 9) |
| <p><i>Inv Peak Current</i></p> | <p>Inverter Peak Current High</p> <p>Reason: The system has detected a high current or dc voltage disturbance and has temporarily shut down. This fault is similar to a current limit fault except that it could not be traced to a specific line. This fault could also be caused if the battery voltage rises above the hardware protection but is still below the high dc voltage setting.</p> <p>Action:</p> <ol style="list-style-type: none"> Carry out Fault Reset Contact Technical Support (see page 9) <p>Note: In automatic mode the inverter will restart 4 times in an attempt to clear this fault.</p> |
| <p><i>Src Sync Fault</i></p> | <p>Source Synchronization Fault</p> <p>Reason:</p> <ol style="list-style-type: none"> The system was not able to synchronize to the source with 30 seconds of the source coming into range. The system will continue attempting to synchronize to the source. The source voltage might be subject to too many disturbances so that the inverter fails to synchronize itself successfully to the source. <p>Action:</p> <ol style="list-style-type: none"> Switch to other Source or wait for source to stabilise Contact Technical Support (see page 9) |

| Fault Message Displayed | Description |
|---|---|
| <i>Load too high</i> | <p>Inverter Load Too High</p> <p>Reason: A manual mode or isolate source command could not be executed because the load is too high. This will only occur if the system was operating in parallel mode (inverter + source) and a function was selected that would render the remaining power source too small.</p> <p>The system will continue in parallel mode and the fault message will reset after 5 minutes.</p> |
| <p><i>High Temp HS1</i> <i>High Temp HS2</i> <i>High Temp HS3</i></p> | <p>High Temperature Heatsink 1, 2 or 3</p> <p>Reason: The inverter heatsink temperature on this machine is too high and the inverter has shut down to protect itself against permanent damage. Load supply will continue from the source only. If no source was available the system will attempt to start and bring on-line a generator.</p> <p>Action:</p> <ol style="list-style-type: none"> Wait 15 minutes for heatsink to cool and carry out Fault Reset If fault continues contact Technical Support (see page 9) <p>Note: In automatic mode the inverter will restart 4 times in an attempt to clear this fault. If fault is not cleared inverter will shutdown.</p> |
| <i>High Temp HS4</i> | <p>High Temperature Solar MPPT Regulator</p> <p>Reason: The solar MPPT regulator heatsink temperature is too high. The system will attempt to reduce this heatsink temperature by reducing the solar power from the MPPT regulator. If the heatsink temperature is still too high the solar regulator is tripped and normal solar regulator operation can only occur after a fault reset has command has been issued.</p> <p>Action:</p> <ol style="list-style-type: none"> Disconnect solar input Wait 15 minutes for heatsink to cool and carry out Fault Reset If fault continues contact Technical Support (see page 9) |

| Fault Message Displayed | Description |
|--|---|
| <i>High Battery Temp</i> | <p>High Battery Temperature</p> <p>Reason:</p> <p>The battery temperature is too high. The system should automatically reduce the battery voltage in an attempt to regulate the battery temperature. This requires the battery temperature compensation and charge voltages to be set up correctly.</p> <p>If the temperature cannot be regulated the system will trip the solar regulator in an attempt to reduce the battery temperature. If still unsuccessful the system will mask the inverter and continue running off a source.</p> <p>Action:</p> <ol style="list-style-type: none"> Disconnect batteries Wait 15 minutes for heatsink to cool and carry out Fault Reset If fault continues contact Technical Support (see page 9) |
| <p><i>Bat Temp Sensor Fault</i></p> <p><i>Heatsink Temp Sensor Fault</i></p> <p><i>Cabinet Temp Sensor Fault</i></p> <p><i>Ambient Temp Sensor Fault</i></p> | <p>Battery, Heatsink, Cabinet or Ambient Temperature Sensor Fault</p> <p>Reason:</p> <p>The sensor is giving an incorrect temperature reading. Check that all wiring from the control box to the inverter modules is securely connected. If this fault cannot be reset contact technical support.</p> <p>Action:</p> <ol style="list-style-type: none"> Carry out Fault Reset If fault continues contact Technical Support (see page 9) |
| <i>High DC Volts</i> | <p>High DC Voltage</p> <p>Reason:</p> <p>The battery voltage has exceeded its safe high limit. The solar regulator will be tripped and if the fault persists the source will be masked. If the condition still persists the inverter is masked eventually.</p> <p>Action:</p> <ol style="list-style-type: none"> Make sure that there are no external DC sources (solar/wind) that are not controlled by the Multi Power Controller system and that could cause the battery to overcharge. If an external AC grid- interactive system is connected, make sure that the 'Inverter Charge Control' setting is enabled and set up correctly (Menu → System Config/Setup → System Setup → Inverter → 126 Inv Chg Max. Carry out Fault Reset If fault continues contact Technical Support (see page 9) |

| Fault Message Displayed | Description |
|-------------------------|---|
| <i>Low DC Volts</i> | <p>Low DC (Battery) Voltage</p> <p>Reason: The battery voltage is below the minimum required voltage and the inverter has shut down. Discharging the batteries further will reduce their capacity and lifespan.</p> <p>Action:</p> <ol style="list-style-type: none"> a. Charge battery immediately to prevent permanent damage to the batteries. b. To charge the batteries: Set the machine to auto and remove any loads. Make sure a source is connected and running. To see if the batteries are charging check screen 2 (System Overview). The top right corner should display either (A-I) or (-BI) to show that the source (A) or (B) is connected in parallel to the inverter (I). The battery current should be positive to charge batteries. <p>Note: After a low DC volts fault the system will automatically clear the fault if a source is on-line and the load is very low. The inverter is then synchronized with this source and the batteries are re-charged. The low DC fault is also cleared if the battery voltage rises above the DC reconnect setting.</p> |
| <i>High DC Amps</i> | <p>High DC (Battery) Amps</p> <p>Reason: The charge current to the batteries is too high and could not be reduced with 10 seconds.</p> <p>Action:</p> <ol style="list-style-type: none"> a. Carry out Fault Reset b. If fault persists the solar regulator could be unable to reduce the import current or the system settings are incorrect. Contact Technical Support (see page 9) |
| <i>Solar Trip</i> | <p>Solar Source Tripped</p> <p>Reason: The battery voltage or temperature could not be reduced and the solar source has been 'tripped' or 'masked' to reduce power to the batteries. This fault can also occur if reverse power is supplied to the generator for too long.</p> <p>Action:</p> <ol style="list-style-type: none"> c. Check Generator settings d. Check Battery settings e. Contact Technical Support (see page 9) |

| Fault Message Displayed | Description |
|--|--|
| <i>Wind Gen Trip</i> | <p>Wind Generator Tripped</p> <p>Reason:</p> <p>The battery voltage or temperature could not be reduced and the wind generator has been 'tripped' or 'masked' to reduce power to the batteries. This fault can also occur if reverse power is supplied to the generator for too long.</p> <p>Action:</p> <ol style="list-style-type: none"> Check Generator settings Check Battery settings Contact Technical Support (see page 9) |
| <i>Low Source A Volts</i> <i>Low Source B Volts</i> | <p>Low Source A or Source B Volts</p> <p>Reason:</p> <p>The voltage on the source that was on-line was too low and out of range and the source has been disconnected. If the source was a generator then the system will attempt to start and connect to it four times. If the fault is still present the system selects another generator as the source.</p> <p>Action:</p> <ol style="list-style-type: none"> Reset source volt or replace source Carry out Fault Reset If fault continues contact Technical Support (see page 9) |
| <i>High Source A Volts</i> <i>High Source B Volts</i> | <p>High Source A or Source B Volts</p> <p>Reason:</p> <p>The voltage from the source that was on-line was too high and out of range and the source has been disconnected. If the source was a generator then the system will attempt to start and connect to it four times. If the fault is still present the system selects another generator as the source.</p> <p>Action:</p> <ol style="list-style-type: none"> Reset source volt or replace source Carry out Fault Reset If fault continues contact Technical Support (see page 9) |
| <i>Low Source A Volts Sag</i> <i>Low Source B Volts Sag</i> | <p>Low Source A or Source B Sag</p> <p>Reason:</p> <p>A sudden drop in the voltage supply from source A or B supply caused the system to disconnect from the source. If the source is a generator, 4 attempts reconnect are made. The source is masked if the fault continues after the fourth attempt.</p> <p>Action:</p> <ol style="list-style-type: none"> Reset source volt or replace source Carry out Fault Reset If fault continues contact Technical Support (see page 9) |

| Fault Message Displayed | Description |
|---|--|
| <p><i>High Source A Volts Surge</i></p> <p><i>High Source B Volts Surge</i></p> | <p>High Source A or Source B Surge</p> <p>Reason:</p> <p>A sudden rise in the voltage supply from source A or B supply caused the system to disconnect from the source. If the source is a generator, 4 attempts reconnect are made. The source is masked if the fault continues after the fourth attempt.</p> <p>Action:</p> <ol style="list-style-type: none"> Reset source volt or replace source Carry out Fault Reset If fault continues contact Technical Support (see page 9) |
| <p><i>Low Source Freq</i></p> | <p>Low Source Frequency</p> <p>Reason:</p> <p>The frequency from the source that was on-line was too low and out of range and the source has been disconnected. If the source was a generator then the system will attempt to start and connect to it four times. If the fault is still present the system selects another generator as the source.</p> <p>Action:</p> <ol style="list-style-type: none"> Reset source volt or replace source Carry out Fault Reset If fault continues contact Technical Support (see page 9) |
| <p><i>High Source Freq</i></p> | <p>High Source Frequency</p> <p>Reason:</p> <p>The frequency from the source that was on-line was too high and out of range and the source has been disconnected. If the source was a generator then the system will attempt to start and connect to it four times. If the fault is still present the system selects another generator as the source.</p> <p>Action:</p> <ol style="list-style-type: none"> Repair or replace source Carry out Fault Reset If fault continues contact Technical Support (see page 9) |
| <p><i>Src A Failed To Start</i></p> <p><i>Src B Failed To Start</i></p> | <p>Source A or Source B Failed to Start</p> <p>Reason:</p> <p>After a start command has been issued to a generator and the warm-up time has expired the generator voltage measured by the system was not in range. The generator is thus stopped again and after the fault reset period another start attempt is made on the same source.</p> <p>The number of start attempts is defined by the 'Cold Start Attempts' setting.</p> <p>Action:</p> <ol style="list-style-type: none"> Repair or replace source Carry out Fault Reset If fault continues contact Technical Support (see page 9) |

| Fault Message Displayed | Description |
|--|---|
| <p><i>Source A Overload</i> <i>Source B Overload</i></p> | <p>Source A or Source B Overload Reason: The load on this source exceeds the source size setting (012 Src A or 013 Src B size). Action:</p> <ol style="list-style-type: none"> Reduce the system load Carry out Fault Reset If fault continues contact Technical Support (see page 9) |
| <p><i>Phase Sequence Fault</i></p> | <p>Phase Sequence Fault Reason: The phase rotation on three phase systems of an active source is wrong. Action: Disconnect the source causing the problem and swap two of the phases to clear the fault.</p> |
| <p><i>Reverse Power Fault</i></p> | <p>Reverse Power Fault Reason: This fault will occur if power was found to be feeding into a generator source. The system will attempt to reduce this reverse power situation and if unsuccessful will disconnect the generator. The system will attempt to recover from this fault 4 times before masking the source. Action:</p> <ol style="list-style-type: none"> Increase either the Generator Reverse Power Limit setting (SP033) or the Generator Reverse Power Fault Time (34) Carry out Fault Reset If fault continues contact Technical Support (see page 9) |
| <p><i>SrcA !Iso SrcB Pwr Lo</i> <i>SrcB !Iso SrcA Pwr Lo</i></p> | <p>Source A Isolation Source B Power Low or Source B Isolation Source A Power Low Reason: Source A or B isolation fail because Source B does not have enough power. This fault will occur when selecting Manual Source B (or A) while in Manual Source A (or B) mode and Source B (or A) does not have the capacity to drive the current load. Action:</p> <ol style="list-style-type: none"> Reduce load or select other source Carry out Fault Reset |

| Fault Message Displayed | Description |
|---|--|
| <p><i>SrcA !Iso SrcB Masked</i></p> <p><i>SrcB !Iso SrcA Masked</i></p> | <p>Source A Isolation Source B Masked or Source B Isolation Source A Masked</p> <p>Reason:</p> <p>Source A (or B) isolation fails because the alternate source was masked. This fault will occur when selecting manual source B (or A) while in manual source A (or B) mode and source B (or A) is masked.</p> <p>Action:</p> <ol style="list-style-type: none"> Select other source Carry out Fault Reset |
| <p><i>SrcA !Iso Inv Pwr Low</i></p> <p><i>SrcB !Iso Inv Pwr Low</i></p> | <p>Source A Isolation Inverter Power Low or Source B Isolation Inverter Power Low</p> <p>Reason:</p> <p>Source A (or B) could not be isolated because the inverter can not supply the load on its own.</p> <p>Action:</p> <ol style="list-style-type: none"> Reduce load or select other source Carry out Fault Reset |
| <p><i>Inverter CB Failed to Close</i></p> | <p>Inverter Contactor Failed to Close</p> <p>Reason:</p> <p>The inverter contactor did not close when required. Could be wiring fault between the control box and the inverter modules</p> <p>Action:</p> <ol style="list-style-type: none"> Carry out Fault Reset If fault continues contact Technical Support (see page 9) |
| <p><i>Inverter CB Failed to Open</i></p> | <p>Inverter Contactor Failed to Open</p> <p>Reason:</p> <p>The inverter contactor did not open when required. Dirty contacts could cause the contactor contacts to be welded closed.</p> <p>Action:</p> <ol style="list-style-type: none"> Carry out Fault Reset If fault continues contact Technical Support (see page 9) |
| <p><i>Inverter CB Spurious Close</i></p> | <p>Inverter Contactor Spurious Closing</p> <p>Reason:</p> <p>The inverter contactor closed when not required to. Could be wiring fault between the control box and the inverter modules</p> <p>Action:</p> <ol style="list-style-type: none"> Carry out Fault Reset If fault continues contact Technical Support (see page 9) |

| Fault Message Displayed | Description |
|--|--|
| <i>Inverter CB Spurious Open</i> | <p>Inverter Contactor Spurious Opening</p> <p>Reason:</p> <p>The inverter contactor opened when not required to. Could be wiring fault between the control box and the inverter modules</p> <p>Action:</p> <ol style="list-style-type: none"> Carry out Fault Reset If fault continues contact Technical Support (see page 9) |
| <i>Source A CB Failed to Close</i> <i>Source B CB Failed to Close</i> | <p>Source A (or B) Contactor Failed to Close</p> <p>Reason:</p> <p>Source A (or B) contactor did not close when not required. Could be wiring fault between the control box and the inverter modules</p> <p>Action:</p> <ol style="list-style-type: none"> Carry out Fault Reset If fault continues contact Technical Support (see page 9) |
| <i>Source A CB Failed to Open</i> <i>Source B CB Failed to Open</i> | <p>Source A (or B) Contactor Failed to Open</p> <p>Reason:</p> <p>Source A (or B) contactor did not open when required. Dirty contacts could cause the contactor contacts to be welded closed.</p> <p>Action:</p> <ol style="list-style-type: none"> Carry out Fault Reset If fault continues contact Technical Support (see page 9) |
| <i>Source A CB Spurious Close</i> <i>Source B CB Spurious Close</i> | <p>Source A (or B) Contactor Spurious Closing</p> <p>Reason:</p> <p>Source A (or B) contactor closed when not required to. Could be wiring fault between the control box and the inverter modules</p> <p>Action:</p> <ol style="list-style-type: none"> Carry out Fault Reset If fault continues contact Technical Support (see page 9) |
| <i>Source A CB Spurious Open</i> <i>Source B CB Spurious Open</i> | <p>Source A (or B) Contactor Spurious Opening</p> <p>Reason:</p> <p>Source A (or B) contactor opened when not required to. Could be wiring fault between the control box and the inverter modules</p> <p>Action:</p> <ol style="list-style-type: none"> Carry out Fault Reset If fault continues contact Technical Support (see page 9) |

| Fault Message Displayed | Description |
|-----------------------------|--|
| <i>Flash Card Fail</i> | <p>Flash Card Failure</p> <p>Reason: Compact Flash Card inside the control box has failed. Logging will be disabled.</p> <p>Action:</p> <ol style="list-style-type: none"> Carry out Fault Reset If fault continues contact Technical Support (see page 9) |
| <i>Modem Fail</i> | <p>Modem Failure</p> <p>Reason: The modem inside the control box has failed. No remote GSM or landline communications are possible.</p> <p>Action:</p> <ol style="list-style-type: none"> Carry out Fault Reset If fault continues contact Technical Support (see page 9) |
| <i>Real Time Clock Fail</i> | <p>Real Time Clock Failure</p> <p>Reason: The real time clock on the controller card inside the control box has failed. The system will no longer be able to keep time.</p> <p>Action:</p> <ol style="list-style-type: none"> Carry out Fault Reset If fault continues contact Technical Support (see page 9) |
| <i>EEPROM Fail</i> | <p><i>EEPROM Failure</i></p> <p>Reason: The non-volatile storage inside the control box has failed. Any changes to Multi Power Controller's settings will not take effect. The system operates with default settings only.</p> <p>Action:</p> <ol style="list-style-type: none"> Carry out Fault Reset If fault continues contact Technical Support (see page 9) |
| <i>Wifi Fail</i> | <p>Wireless Communications Failure</p> <p>Reason: The Wi-Fi bridge inside the control box has failed. No remote Wi-Fi communications will be possible.</p> <p>Action:</p> <ol style="list-style-type: none"> Carry out Fault Reset If fault continues contact Technical Support (see page 9) |

| Fault Message Displayed | Description |
|---------------------------------|--|
| <i>Power Supply Fail</i> | <p>Power Supply Failure</p> <p>Reason: A power supply on the controller card in the Control Unit has failed.</p> <p>Action:</p> <ol style="list-style-type: none"> Carry out Fault Reset If fault continues contact Technical Support (see page 9) |
| <i>Comms Bus Fault</i> | <p>Communications Failure</p> <p>Reason: A communications fault has occurred on the control card in the Control Box. The system continues running although user commands from the keypad or PC based user interface are unreliable and will execute slower than usual.</p> <p>Action:</p> <ol style="list-style-type: none"> Carry out Fault Reset If fault continues contact Technical Support (see page 9) |
| <i>CT fail</i> | <p>Current Transformer Failure</p> <p>Reason: A Current Transformer (CT) fault will occur if the system which is connected in parallel with the source is trying to export or import power from the source but reads zero KW for a long period from the current sensor. The source will be disconnected and masked after the fault reset period.</p> <p>Action:</p> <ol style="list-style-type: none"> Carry out Fault Reset If fault continues contact Technical Support (see page 9) |
| <i>Shunt Cal Fail</i> | <p>Shunt Calibration Failure</p> <p>Reason: Every time the system boots up and if a solar MPPT regulator is installed, the system will attempt to calibrate the solar current sensor. If the sensor can not be calibrated successfully this fault is displayed and the solar regulator will not be activated.</p> <p>Action:</p> <ol style="list-style-type: none"> Power down and restart system If fault continues contact Technical Support (see page 9) |
| <i>Smart Load Setting Fault</i> | <p>Smart Load Setting Fault</p> <p>Reason: The smart load has been set up incorrectly. Some settings may be conflicting and are preventing correct smart load operation.</p> <p>Action:</p> <ol style="list-style-type: none"> Check all smart load related settings Carry out Fault Reset If fault continues contact Technical Support (see page 9) |

8.3.1 Event Messages

Table 10: Event Messages

| Event Message Displayed | Description |
|---------------------------|---|
| Waiting | The system is idle and ready for any event to occur. |
| System Initialise | Displayed after initial power up or a system reset. |
| Fault Reset | User has instigated a fault reset as to acknowledge all faults and unmask all peripherals. |
| Emergency Stop | Emergency Stop has been asserted. No control functions can be performed. |
| System Off | System has been switched off manually. |
| System Fail | System has been switched off due to a major system failure. |
| Generator not Available | The generator is currently not available because is in not configured, masked or the grid source is on-line |
| Inv Start: Reconnect Volt | Inverter has started as the battery voltage has risen above the DC reconnect threshold. |
| Inv Started | Inverter has started but it is not on line yet |
| Man Inv Only | System is in manual inverter only mode (Inverter is the only source on line) |
| Auto Inv Only | System is in auto inverter only mode (Inverter is the only source on line, but other sources can be brought on-line automatically) |
| Sync OK | Correct synchronization has been achieved between the Inverter and Source A or Source B before the relative source can come on line |
| Inv Stopped | Inverter has been stopped. |
| Inv Masked | Inverter has been masked. It can not be used by the system any more unless as fault reset is manually or automatically issued. |
| Inv Unmasked | The fault on the inverter module has been either manually or automatically cleared. |
| Inv CB Closed | Inverter contactor has closed after the contactor coil has been energized. |
| Inv CB Opened | Inverter contactor has opened after the contactor coil has been de-energized. |
| Inv Ramp Down | Signifies inverter power is ramping down to before disconnecting whilst in parallel mode. |
| Inv Fan Start | Inverter heat sink fan has been started to cool the inverter. |
| Inv Fan Stop | Inverter heat sink fan has been turned off as temperature is low enough. |
| Gen Start Src Fail | Generator start as other source has failed. |
| Start Src A | Source A has been called to start either automatically or by selection of Manual source A only from the keypad. |
| Start Src B | Source B has been called to start either automatically or by selection of Manual source B only from the keypad. |

| Event Message Displayed | Description |
|-------------------------|---|
| Gen Start Low Batt | Generator is signaled to start as the battery voltage is less than the battery low threshold. |
| Gen Start High Load | Source A (or B) is signaled to start as the inverter/phase loading (site) is higher than the settable generator start on inverter load threshold |
| Gen Start Inv Fail | Source A (or B) is signaled to start as the inverter can no longer supply the load |
| Gen Start Timed Start | Source A (or B) is signaled to start as the generator periodic start period has expired |
| Gen Start Equalize | Source A (or B) is signaled to start as the equalization period and the maximum delay to equalize have expired. Batteries will be charged in equalize charge. |
| Force Start Gen | Signifies that the external Force Generator Start on the input has been asserted or Force Start A (B) from the keypad has been instigated for Source A or B to start. This can only be whilst the system is in AUTO mode. |
| Src A Warming Up | Source A is in its warm-up cycle. |
| Src B Warming Up | Source B is in its warm-up cycle. |
| Src is in Spec | Source started is found to be in spec. If the source is a utility supply this message signifies that the source was found to be in range and will be used. |
| Auto Src A Only | System in 'Automatic Source Only' mode(Source A is the only source on line) |
| Auto Src B Only | System in 'Automatic Source Only' mode(Source B is the only source on line) |
| Man Src A Only | System in 'Manual Source Only' mode (Source A is the only source on line). The inverter will not be brought on-line automatically. |
| Man Src B Only | System in 'Manual Source Only' mode (Source B is the only source on line). The inverter will not be brought on-line automatically. |
| Parallel | Inverter module is in parallel with either Source A or B. |
| Src Ramp Down | Signifies Source A or B power is ramping down before disconnecting. |
| Src A Cooling Down | Source A is cooling down for the duration of the cool down period. If the source is a utility the cool down period is less than 20 seconds. |
| Src B Cooling Down | Source B is cooling down for the duration of the cool down period. If the source is a utility the cool down period is less than 20 seconds. |
| Src A CB Closed | Source A contactor has closed after the contactor coil has been energized. |
| Src B CB Closed | Source B contactor has closed after the contactor coil has been energized. |
| Src A CB Opened | Source A contactor has opened after the contactor coil has been de-energized. Also indicates that batteries are discharging. |

| Event Message Displayed | Description |
|--------------------------------|--|
| Src B CB Opened | Source B contactor has opened after the contactor coil has been de-energized. Also indicates that batteries are discharging. |
| Src Stop High AC V | Source (Utility) has been stopped because it is out of range: AC Volts too high |
| Src Stop Low AC V | Source (Utility) has been stopped because it is out of range: AC Volts too low |
| Src Stop High Freq | Source (Utility) has been stopped because it is out of range: Frequency too high |
| Src Stop Low Freq | Source (Utility) has been stopped because it is out of range: Frequency too low |
| Src Stop High DC | Source (Utility) has been stopped because it is out of range: DC Voltage too high |
| Island Detect | Source has been stopped because it is out of range: Islanding detected. |
| Gen Stop Low load | Source (Generator) has been stopped because the generator loading and battery charge rate are very low. |
| Gen Stop Batt Chgd | System has completed a battery charge cycle and the generator stop conditions have been met as to bring the generator off line |
| Src A Stopped | Source A has finished its cool down period and stopped |
| Src B Stopped | Source B has finished its cool down period and stopped |
| Src A Masked | Source A has been masked |
| Src B Masked | Source B has been masked |
| Src A Unmasked | The fault on Source A has been either manually or automatically cleared |
| Src B Unmasked | The fault on Source B has been either manually or automatically cleared |
| Src A Isolated | Source A has been manually isolated from use |
| Src B Isolated | Source B has been manually isolated from use |
| Src A Isolate Fail | Unable to Isolate Source A as the site load may be too high for the inverter module |
| Src B Isolate Fail | Unable to Isolate Source B as the site load may be too high for the inverter module |
| Src A Re Enable | Source A has been manually made available again for use |
| Src B Re Enable | Source B has been manually made available again for use |
| Src A Bypass | Source A has been switched to bypass. Bypass is detected by means of a normally closed contact connected to the bypass switch. |
| Src B Bypass | Source B has been switched to bypass. Bypass is detected by means of a normally closed contact connected to the bypass switch. |
| Gen Stop Grid OK | Stop generator as the grid is back in spec and can be used |
| Batt Chg Stage 0 | No source on line and battery charging is not occurring from the source |
| Batt Chg Stage 1 | Signifies that battery charging has commenced from one of the sources |

| Event Message Displayed | Description |
|--------------------------------|---|
| Batt Chg Stage 2 | Signifies that the 'Bulk' or 'Equalize' charge level has been achieved |
| Batt Chg Stage 2B | Signifies that the 'Extended Equalize' mode has been implemented |
| Batt Chg Stage 3 | Signifies that the 'Bulk' or 'Equalize' or Extended Equalize' charge has terminated. |
| Batt Chg Stage 4 | Signifies that the system is in a 'Float' charge stage |
| Settings Retrieved | Default settings have been uploaded |
| Inverter Take Power | Inverter takes all power and reduce source power to zero without disconnecting from source |
| Low Batt Bulk Enabl | Battery voltage has dropped below the bulk charge enable threshold. If the bulk charge time was not set to 00h00 the next charge will be a bulk charge done only at the bulk charge time. |
| Manual Equalise ON | Equalise Mode has been manually selected by the operator. |
| Auto Equalise ON | Equalise Mode has be automatically selected. |
| Manual Equalise OFF | Equalise Mode has been manually de-selected by the operator. |
| Solar Cntrl Enabled | Solar Control Mode has been enabled battery and charging from the source on line will be reduced. Excess Solar energy can be exported to the utility supply if on line |
| Solar Cntrl Disable | Solar Control Mode has been disabled and the inverter will recommence charging the batteries from the source that is on line |
| Aux Control Enabled | Auxiliary Control Mode has been enabled battery and charging from the source on line will be reduced. Excess Solar energy can be exported to the utility supply if on line |
| Aux Cntrl Disabled | Auxiliary Control Mode has been disabled and the inverter will recommence charging the batteries from the source that is on line |
| MPPT Sweep Progress | Solar MPPT sweep in progress. |
| Auto Calibrate MPPT | Calibration of MPPT Solar regulator in progress. This may take up to 5 minutes. |
| MPPT Control Active | MPPT control is active. |
| Time Updated | The system time has been updated. |
| Event Log Clear | All event logs have been cleared. |
| Data Log Clear | All data logs have been cleared. |
| Rmt GSM conn | Remote GSM connection has been established to the system. |
| Rmt GSM disconn | Remote GSM connection has been terminated. |
| Rmt WiFi conn | Remote WiFi Connection has been established to the system. |
| Rmt WiFi disconn | Remote WiFi connection has been terminated. |
| Settings Saved | All settings have been successfully saved to non-volatile memory. |
| Low Solar Rad | Solar radiation too low. This status will show when the MPPT regulator disconnects from as a result of low solar radiation. |

| Event Message Displayed | Description |
|-------------------------|---|
| Solar Rad OK | Solar radiation is OK. This status is shown when the solar radiation has reached its required level and the MPPT regulator can start up. |
| Firmware Up HMI | System firmware on HMI has been updated. |
| Firmware Up GSM | System firmware on GSM has been updated. |
| Firmware Up Wifi | System firmware on WIFI has been updated. |
| Firmware Up DSP | System firmware on DSP has been updated. |
| Firmware Up MIC | System firmware on MIC has been updated. |
| Summation Cleared | All summation logs have been cleared. |
| Solar Charge Limit | Solar controller limits the charge rate. When this status is shown there is more solar power available than what the system is allowed to export to the grid or the AC load. |
| WiFi Initialize | WiFi Controller Initialized. |
| Modem Initialize | Modem Controller Initialized. |
| HMI Initialize | HMI (Keypad) Controller Initialized. |
| Smart-Load Count Up | Smart-Load count increased. This means that more non-critical loads are now connected to the inverter. Non-critical loads may have up to 5 levels of priority when using RF (radio controlled) or 3 locally controlled loads. |
| Smart-Load Count Down | Smart-Load count decreased. This means that less non-critical loads are now connected to the inverter. Non-critical loads may have up to 5 levels of priority when using RF (radio controlled) or 3 locally controlled loads. |

9. Glossary

| | |
|-----|---|
| AC | Alternating current. The utility, generators, and inverters can supply AC. The AC voltage to homes in South Africa is described as 230V AC 50Hz meaning 230V RMS that is alternating between a positive voltage and a negative voltage 50 times a second. |
| CIC | Control interface card |
| CT | A Current Transformer (CT) is used for measurement of electric currents. When current in a circuit is too high to directly apply to measuring instruments, a current transformer produces a reduced current accurately proportional to the current in the circuit, which can be connected to measuring and recording instruments. A current transformer also isolates the measuring instruments from what may be very high voltage in the primary circuit. |
| DC | Direct current. Batteries, solar panels (PV) and wind turbines provide DC. The DC voltage for most battery banks is 50V meaning that the voltage between terminals of a battery are always positive. Our inverters can take 50V DC from batteries and output 230V AC to supply homes and businesses. |
| DSP | Digital signal processor. |

| | |
|---------------------------|--|
| EEPROM | EEPROM (also written E ² PROM and pronounced e-e-prom or simply e-squared), which stands for Electrically Erasable Programmable Read-Only Memory, is a type of non-volatile memory used in computers and other electronic devices to store small amounts of data that must be saved when power is removed, e.g., calibration tables or device configuration. |
| Equalisation | Individual batteries and individual cells within lead acid batteries react differently to being charged. Over time battery performance will drop as differences become more pronounced. At this stage it is necessary to perform an equalization charge (or refreshing charge) - usually once every 10 cycles, at least once per month An equalization charge must only be performed on vented (not sealed) flooded lead acid batteries. |
| Generator | This is a machine that usually runs off diesel or petrol to provide AC power. Generators are usually only run when needed. A generator will be configured as a generator if the generator can be started remotely or a utility if the generator needs human intervention to start it. Generators need to be run periodically to keep their moving parts functional. Generators usually provide most power per litre when they are electrically loaded to 80% of their rating. Obviously running a generator for longer than necessary will waste fuel and shorten its lifetime, if the generator is run for too short a period the generator lifetime is reduced, this is called the generator minimum run time. |
| Grid | The main AC input of the inverter. A grid can be provided by the utility company or a machine like a generator. The grid inputs of our inverters are called source A and source B. Any two grids can be connected to the source A/B inputs. |
| HMI | Human machine interface - The technical name for both the screen and keypad combination with all the menus and screens for controlling the inverter (machine). |
| HPU | Hybrid power unit. A bi-directional inverter that does not offer grid voltage correction and takes power from a large generator, solar PV array and battery bank. |
| Line 1,2, 3 L1, L2, L3 | "Line" refers to the AC live wire that feeds power from the source to the inverter module or to the load. If a inverter has more than 1 module they are numbered as 1, 2 and/or 3 from the top. SRC A L1 for example would be the 1 st phase live wire from source A to the inverter module (terminal labeled SRC A). |
| Masked | The peripheral has been permanently disabled and turned off by the system. Only a fault reset will unmask and retry the possibly faulty peripheral such as inverter, source or solar regulator. |
| MOSFET | Metal-Oxide Semiconductor Field-Effect Transistor. Devices used in the inverter's power amplifier. |
| MPC | Multi power controller. A bi-directional inverter that offers grid voltage correction and takes power from the utility, generator solar PV and batteries. |
| MPPT | Maximum power point tracking, used to improve the efficiency of PV panels by about 30%. |
| Phase | There are single phase or three phase machines and loads. A three phase machine cannot be run off a single phase. Proper description of phases is beyond the scope of this manual. |
| PV | Photo voltaic cell. Also know as solar panels. PV cells generate DC electricity when sunlight strikes them. |
| SCADA | Supervisory Control And Data Acquisition. This is a computer used to monitor and control machines or hardware. |

| | |
|---------------|--|
| SRC or SOURCE | A source (abbreviated as SRC) is the general definition for an AC supply such as the Grid or a Generator. |
| Utility | This is an AC power source that is usually will be present most of the time. The utility is often provided by some power producing company and is not always reliable due to lack of capacity. |
| WiFi | Wi-Fi (short for "wireless fidelity") is a term for certain types of wireless local area network (WLAN) that use specifications in the 802.11 family. The term Wi-Fi was created by an organization called the Wi-Fi Alliance, which oversees tests that certify product interoperability. A product that passes the alliance tests is given the label "Wi-Fi certified" (a registered trademark). |
| Wind Turbine | This is a modern form of wind mill. Wind turbines generate electricity when their blades are rotated by the wind. Wind turbines usually generate DC. |